

PHV Series Designer. Horizontal and Vertical

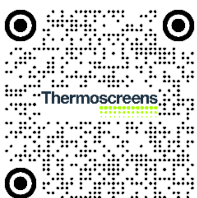

INSTALLATION, OPERATION AND MAINTENANCE INSTRUCTIONS



Scan to download the
user guide and App

English

1. CONTENTS

	Page
1. CONTENTS.....	2
2. ELECTRICAL SAFETY	3
3. SPECIFICATIONS	4
4. INTRODUCTION.....	5
5. DELIVERY CONTENTS.....	6
6. TOOLS REQUIRED	6
7. INSTALLATION.....	7
8. LPHW MODELS.....	10
9. REMOTE CONTROL INSTALLATION	11
10. REMOTE CONTROL SETTINGS	11
11. EXTERNAL CONTROLS	12
12. MULTIPLE AIR CURTAIN SYSTEMS.....	14
13. SYSTEM CONFIGURATION	15
14. FAN SPEED SELECTION.....	16
15. REMOTE CONTROL OPERATION	17
16. COMMISSIONING THE SYSTEM	18
17. SIGN OFF	19
18. FAULT CONDITIONS	20
19. SERVICE & MAINTENANCE	21
20. WARRANTY.....	22
APPENDIX 1A — DIMENSIONS OF HORIZONTAL AIR CURTAIN (WALL MOUNTED)	23
APPENDIX 1B — DIMENSIONS OF HORIZONTAL AIR CURTAIN (CEILING MOUNTED)	24
APPENDIX 2 — DIMENSIONS OF VERTICAL AIR CURTAIN	25
APPENDIX 3A — WIRING DIAGRAM PHVD1000E and PHVD1000E V	26
APPENDIX 3B — WIRING DIAGRAM PHVD1500E and PHVD1500E V	27
APPENDIX 3C — WIRING DIAGRAM PHVD2000E and PHVD2000E V	28
APPENDIX 3D — WIRING DIAGRAM PHVD1000W, PHVD1500W, PHVD2000W, PHVD1000W V, PHVD1500W V and PHVD2000W V	29
APPENDIX 3E — WIRING DIAGRAM PHVD1000A, PHVD1500A, PHVD2000A, PHVD1000A V, PHVD1500A V and PHVD2000A V	30
21. DECLARATION OF CONFORMITY	31

2. ELECTRICAL SAFETY

Electrical Supply and Wiring to the Air Curtain

All electrical wiring and connections MUST be carried out by a competent qualified electrician in accordance with the latest edition of national and local wiring regulations and/or local statutory regulations. **“Danger: Disconnect electrical supply before servicing”**

- A 1 phase or 3 phase local isolator having a contact separation of at least 3mm on all poles must be fitted in the electrical supply to the air curtain and located in an accessible position adjacent to the unit.
- The appliance must be connected by cables having an appropriate heat resistant temperature rating. Electrical connection entry point for horizontal Designer PHV air curtain is from the left hand side of the air curtain, refer Appendix 1. The adjacent picture details optional electrical connection entry points for vertical Designer PHV models. Power and control cables for vertical units should be separately threaded up via the cable trunking provided (see insert).

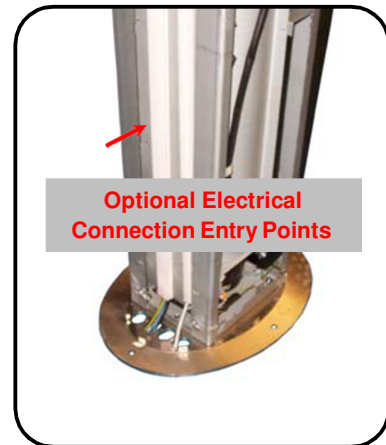

- All supply cables, circuit breakers and other electrical installation equipment must be correctly sized for the air curtain model being installed; see section 3: Specifications.
- Models operating on a 3 phase electrical supply - see section 3: Specifications - require a neutral connection (3N~).
- A 25mm size cable gland or conduit connector of IP21 rating or above should be used for the Electrical Supply into the air curtain.
- See Wiring Diagrams for connecting electrical supply and control cables to the air curtain. The air curtain must be earthed.

3 SPECIFICATIONS

Table 1

Air Curtain	Electrical Supply (V/ph/Hz)	Rated Power Input (kW)	Current per phase (A)	Heat Output [Low/High] (kW)	Weight (kg)	
PHVD1000A	230/1/50	0.30	1.5	-	54	
PHVD1500A, PHVD1500A V	230/1/50	0.40	1.8	-	67	
PHVD2000A, PHVD2000A V	230/1/50	0.60	2.9	-	93	
PHVD2500A V (Stacked Unit)	Top air curtain	230/1/50	0.30	1.5	-	121
	Bottom air curtain	230/1/50	0.40	1.8	-	
PHVD3000A V (Stacked Unit)	Top air curtain	230/1/50	0.30	1.5	-	147
	Bottom air curtain	230/1/50	0.60	2.9	-	
PHVD1000W	230/1/50	0.30	1.3	6.0/12.0	61	
PHVD1500W, PHVD1500W V	230/1/50	0.40	1.8	9.0/18.0	82	
PHVD2000W, PHVD2000W V	230/1/50	0.60	2.7	12.0/24.0	107	
PHVD2500W V (Stacked Unit)	Top air curtain	230/1/50	0.30	1.3	15/30	143
	Bottom air curtain	230/1/50	0.40	1.8		
PHVD3000W V (Stacked Unit)	Top air curtain	230/1/50	0.30	1.3	18/36	168
	Bottom air curtain	230/1/50	0.60	2.7		
PHVD1000E	400/3/50	12.30	18.7	6.0/12.0	57	
PHVD1500E, PHVD1500E V	400/3/50	18.40	27.9	9.0/18.0	71	
PHVD2000E, PHVD2000E V	400/3/50	24.60	37.5	12.0/24.0	99	
PHVD2500E V (Stacked Unit)	Top air curtain	400/3/50	12.30	18.7	15/30	128
	Bottom air curtain	400/3/50	18.40	27.9		
PHVD3000E V (Stacked Unit)	Top air curtain	400/3/50	12.30	18.7	18/36	156
	Bottom air curtain	400/3/50	24.60	37.5		

4. INTRODUCTION

Established in the 1960s, Thermoscreens is a leading air curtain manufacturer that exports to over 60 countries worldwide.

As with all our products, the Designer PHV range of air curtains is designed with energy efficiency in mind.

Designer PHV models suffixed E, W or A are designed to be surface mounted inside a building, located horizontally over a doorway or vertical close to door opening.

They must not be installed on the outside of a building or built into a cabinet or recessed in any way.

Please complete the following details for your reference:

Date of Purchase
Place of Purchase
Serial Number

Proof of purchase is required to make a claim under warranty.



Thermoscreens
St. Mary's Road
Nuneaton
Warwickshire
England
CV11 5AU

Email: sales@thermoscreens.com — <http://www.thermoscreens.com>

Tel: +44 (0) 24 7638 4646 — Fax: +44 (0) 24 7638 8578

5. DELIVERY CONTENTS

The following items are supplied in the box at delivery.

NOTE: If any parts are missing or damaged contact your place of purchase.

Designer PHV Air Curtain



Horizontal or vertical plus fittings

Touch Remote Control



Supplied with 6m RJ Control Cable

Accessories

Spare M4 socket button screws
2.5mm hexagon key wrench
M10 stainless steel dome nuts
(vertical unit)
M8 stainless steel dome nuts
(horizontal unit)
Fixing kits (if applicable)
RJ extension lead (vertical unit)

Outdoor Air Thermostat (Optional – supplied by Installer)



Used for simple weather compensation control
(disables heating on a warmer day)

6. TOOLS REQUIRED

The following tools are required for installation:

- Flat blade screwdrivers
- Pozi head screwdrivers
- 10mm spanner
- Adjustable spanner
- Electric drill
- Ladders
- Appropriate lifting equipment

7. INSTALLATION

The Designer PHV air curtain should be surface mounted horizontally over a doorway and not exposed to the external environment or moist conditions. It should not be built-in or recessed in any way.

7.1 Horizontal Installation

Ensure that the unit is mounted within its height specification of 1.8m to 3.5m maximum (from floor level to the underside of the unit) with the air discharge grille positioned nearest to the door.

- The air curtain should be located as close to the door opening as possible for best performance, obstructions such as door opening devices, structural beams etc. will reduce the efficiency of the air curtain.
- There must be at least 200mm clearance at the air inlet for air to enter the unit, see Appendix 1a and Appendix 1b.

NOTE: For the air curtain to work well the width of the open doorway should be less than the length of the air curtain.

7.1.1 Wall or Ceiling Fixing

Using the 2.5mm hexagon key wrench supplied, unfasten and remove casing screws from the Designer PHV unit and carefully detach the back and inlet grille panels. All screws should be kept safe as they will be required later in the installation.



Fig 1

Designer PHV horizontal air curtains are supplied with two stainless steel wall or ceiling brackets fitted to each end of the unit. Refer to Appendix 1A and Appendix 1B for mounting details. Drill the wall accordingly and secure the unit above the door. Ensure all fixings are correctly fitted and tightened.

NOTE: Use suitable fixing bolts (not supplied) to fix the unit to the wall or ceiling, taking into account the type of wall/ceiling and the weight of the unit (see section 3: Specifications).



Fig 2

ATTENTION: For stainless steel units the inlet grille and back panels are coated in an easy to peel protective film. Please ensure all the protective film is removed before the air curtain is put into service. For clarity, all photographs in the instructions show the stainless steel sheet with the protective film already removed.

For multiple air curtains joined together over a doorway an additional wall bracket (T6811940) or ceiling bracket (T6811950) must be fitted at each joining point, see Fig 3. Back and inlet grille panels should only be fitted after all functional tests have been completed and verified (See Commissioning).

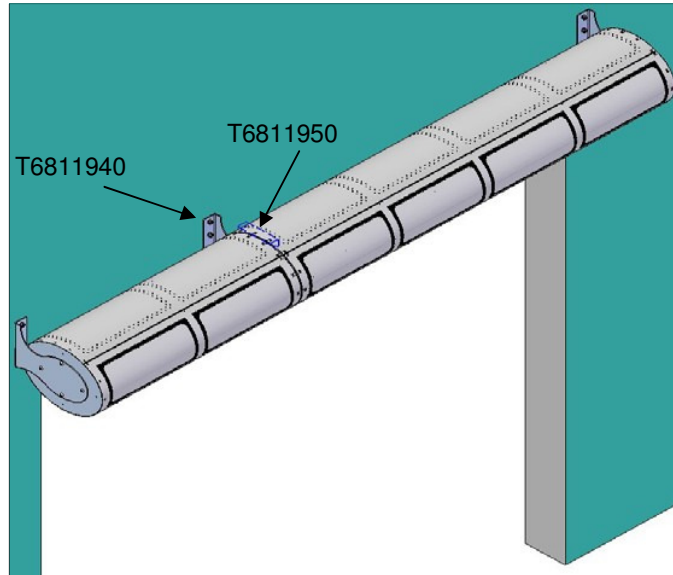

Fig 3

7.2 Vertical Installation

Prior to commencing any vertical installation it is essential to ensure the correct handing Designer PHV unit(s) have been selected.

The air curtain is located close to the door opening with the base plate touching the wall (see Fig 4) and with the air discharge grille positioned nearest to the door (see “Handing Guide” in Appendix 2). Maximum doorway width = 2m per air curtain. For maximum effectiveness it is essential to ensure the height of the air curtain is slightly higher than the opening height of the door. Obstructions such as door opening devices, structural beams etc. will reduce the efficiency of the air curtain. There must be at least 200mm clearance at the air inlet for air to enter the unit, see Appendix 2.

7.2.1 Floor Fixing

Using the 2.5mm hexagon key wrench supplied, unfasten and remove casing screws from the Designer PHV unit and carefully detach the back and inlet grille panels. All screws should be kept safe as they will be required later in the installation.

Before installing the Designer PHV unit obtain four suitable fixing bolts, taking into account floor type and unit weight (see section 3: Specifications). Rawlplug[®] M10 Projecting Rawlbolt[®] 44356 type may be suitable. For dimensional details refer to the general assembly drawing, see Appendix 2.

Designer PHV vertical air curtains are supplied with the base plate fitted. Determine and place the unit at its most favourable position. A wall bracket must be fitted to the top of the unit for PHVD2000V and PHVD2500V air curtains to tether the top of the unit to the wall. In order to use the wall bracket supplied ensure the back of the base plate touches against the wall.

Using the base plate as a template, mark the location of the four holes, as indicated in the adjacent picture.

Using a suitable masonry drill bit correctly drill the four marked out holes. Place M10 fixing bolts into each hole, ensuring all bolts are upright.



Fig 4

Reposition the air curtain base plate over the projecting bolts. Tighten each M10 nut as indicated in the adjacent picture. Ensure the vertical unit is secure, level and square.



Fig 5

Using a hacksaw carefully cut the projecting bolt flush with the nut, ensuring the base plate is not damaged or marked in any way.

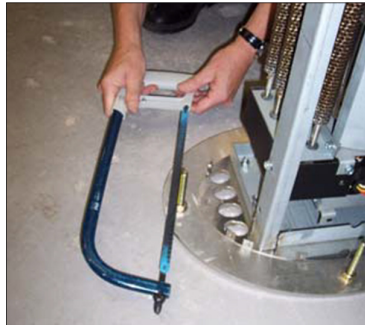

Fig 6

Remove only one M10 nut and refit and secure bolt with a stainless steel M10 dome nut supplied. Repeat for each of the other three projecting bolts one at a time.

Back and inlet grille panels should only be fitted after all functional tests have been completed and verified (See Commissioning).



Fig 7

7.2.2 Stacking Air Curtain

Only a single 1.0m stacking vertical air curtain should be mounted on top of another vertical unit. The maximum overall height for stacking is 2.78m (1.5m + 1.0m vertical). All units higher than 1.5m must be secured with a wall bracket at the top of the stack.

Using fixing kit components supplied the vertical stack frames are joined together using M8 x 25mm hexagonal bolts and M8 nyloc nuts (see Fig 8).

ATTENTION: For stainless steel units the inlet grille and back panels are coated in an easy to peel protective film. Please ensure all the protective film is removed before the air curtain is put into service. For clarity, all photographs in the instructions show the stainless steel sheet with the protective film already removed.

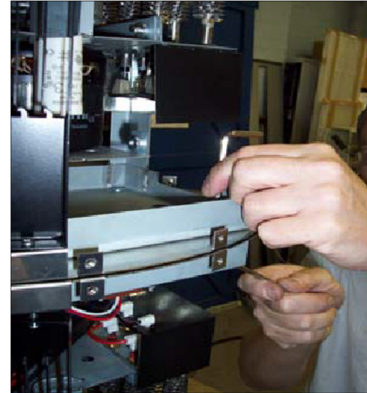

Fig 8

8. LPHW MODELS

For the design of the water pipework system and pump, water flow rates and pressure drops for maximum heat output of the air curtain are given in Table 2 below.

Table 2

Air Curtain	2 row coil (based on 82/71°C)		3 row coil (based on 60/40°C)	
	Water Flow Rate (l/min)	Water Pressure Drop (kPa)	Water Flow Rate (l/min)	Water Pressure Drop (kPa)
PHVD1000W	15.6	4.9	8.6	9.8
PHVD1500W	23.4	9.3	12.9	10.0
PHVD2000W	31.2	14.9	17.1	18.4

NOTE: Water flow rates and pressure drops at different water temperatures can be calculated using the Thermoscreens coil calculation programme. Visit the Thermoscreens website for details.

For LPHW models ensure suitable water mains isolation valves, as Fig 9, are fitted to both the flow and return pipework

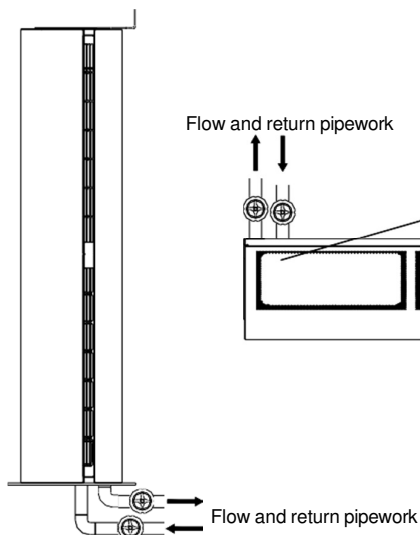

Fig 9

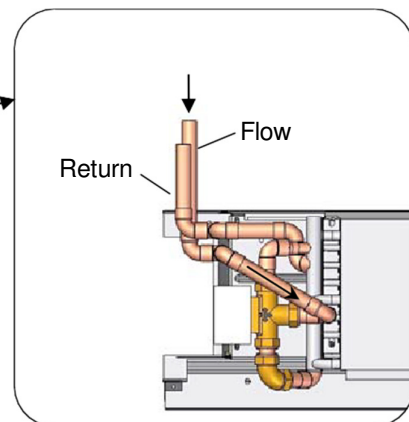

Fig 10

9. REMOTE CONTROL INSTALLATION

Mount the Touch Controller in a convenient position directly to the wall or onto a switch box.

9.1 Wall mounting

- Step 1** Press release button on side of Controller case and pull the back case away (see Fig 11).
- Step 2** Feed one end of the RJ control cable through the back case, secure it, then screw the back case to the wall using suitable fixings (not supplied).
- Step 3** Connect the RJ plug to the RJ socket on the PCB in the remote control.
- Step 4** Refit the front case.

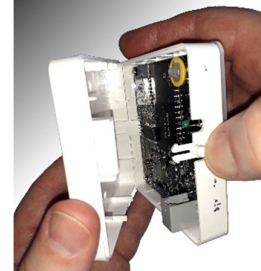

Fig 11

9.2 Switch box mounting

- Step 1** Press release button on side of Controller case and pull the back case away (see Fig 11).
- Step 2** Feed one end of the RJ control cable through the switch box, feed and secure the RJ control cable through the back case and secure back case to switch box using 2 mounting screws (not supplied) (see Fig 12).
- Step 3** Connect the RJ plug to the RJ socket on the PCB in the remote control.
- Step 4** Refit the front case.

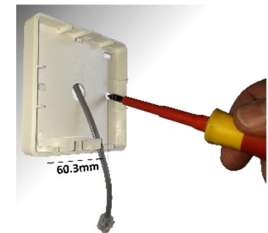

Fig 12

10. REMOTE CONTROL SETTINGS

Touch Controller with four default software Flag settings provide following optional features, as Table 3. If required, software Flag values can be changed by entering advanced settings as below.

With Controller ON, long press both Up and Down touchpad – 01 Flag menu displayed on screen
Tap Home touchpad to detail Flag 01 Reset on power-up

Follow instructions on LCD screen with:

- Tap Speed touchpad to cycle Flags 1 to 4
- Tap Up or Down touchpad to change selected Flag value

Tap Home touchpad to confirm value

Table 3

FLAG	Feature	Explanation	Default	Notes
1	Reset on power-up	On restoring power after an electrical interruption all Remote Control settings are retained	01 (ON)	WARNING! – Fans start on their own after power is restored
2	Stop fan on cold	Fans are switched off when heating level is achieved (AUTO mode only)	00 (OFF)	
3	Never blow cold	Air curtain always heats in AUTO mode	00 (OFF)	Will not go to ambient mode
4	Room air temperature control	Enables the room air sensor in the Remote Control	00 (OFF)	Disables all other temperature sensors

11. EXTERNAL CONTROLS

11.1 Remote switch contacts IN0, IN1

Terminals IN0 and IN1 on the CCS PCB inside the air curtain can be used to provide different control strategies using remote volt-free contacts (see Fig 13). This could be to provide remote On/Off from a timer or BMS Digital/Output contact, to work with a door switch or for simple weather compensation control to disable heating when outdoor air temperatures become warmer. Table 4 describes the different functions:

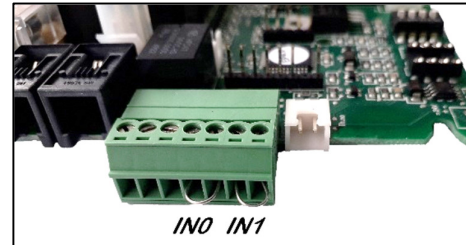







Fig 13

Table 4

Function	IN0		Notes
			
Remote On/Off (INHIBIT)	Unit operates normally in MANUAL Mode or AUTO Mode from the Remote Control	Unit switches off after 15s, with fan run-on at Medium fan speed if DIP 2 = OFF	Use the Remote Control to set up unit and then hide it away if required. * On/Off is then done via IN0 using a remote volt-free contact.

Function	IN1		DIP 4	IN0	Notes
					
Door Switch Control	After 30s the heating is disabled and the fan goes to low speed	Unit operates normally in MANUAL Mode or AUTO Mode from the Remote Control	ON		Door Open:- Normal Control Door Closed:- Heating Off Low Fan Speed
Summer Winter	Unit operates normally in MANUAL Mode or AUTO Mode from the Remote Control <i>COLD DAY</i>	Heating is disabled straight away, Fan speeds operate normally from the Remote Control <i>WARM DAY</i>	OFF		Simple weather compensation control using an outdoor air thermostat with volt free contacts (see Section 11.3)

NOTE: Wire volt-free, remote switch contacts to 2-way screw terminals IN0 and IN1 using 2-core cable.
WARNING: Do not apply any voltage to terminals IN0 and IN1 as this will damage the CCS PCB inside the air curtain.
* NOTE: The Controller must stay plugged-in for the air curtain to keep working. An optional plug-in EEPROM is available from Thermoscreens so the Remote Control can be unplugged and the air curtain stay working. Visit the Thermoscreens website for details.

11.2 Overheat safety cut-out indication

For electric heated air curtains the CCS PCB includes a fault indication signal for if the overheat safety cut-out on the electric heater operates.

Volt free changeover contacts (1A 240VAC 30VDC) can be wired via the 7-way screw terminal (see Fig 14).

Refer to Section 18.1: Overheat Safety cut out, for how to reset a overheat safety cut-out situation.

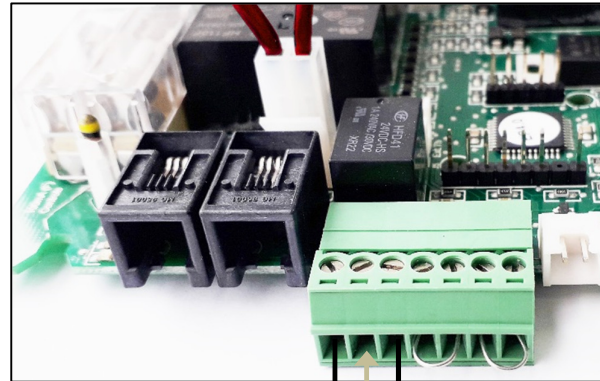

Fig 14

NO
HEALTHY
NC
ALARM!
C

11.3 Weather compensation control (Summer/Winter)

To save heating energy on warmer days a simple weather compensation (Summer/Winter) heat control strategy can be used. Fit an outdoor air thermostat with volt-free contacts (supplied by the installer) to a north facing wall.

Use a 2-core cable to connect the outdoor air thermostat to 2-way terminal IN1 on the CCS PCB (see Fig 15)

On the CCS PCB, set DIP 4 to OFF as per Table 4, (see Section 11.1: Remote switch contacts IN0, IN1).

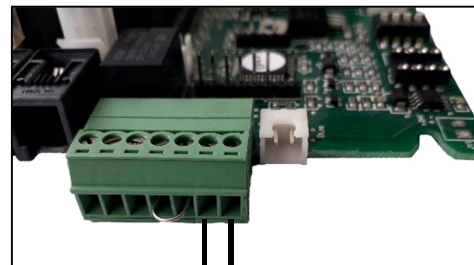

Fig 15

Switch Contact Closed = Heating Enabled (cold day)
Switch Contact Open = Heating Disabled (warm day)



NOTE: Wire volt-free, remote switch contacts to 2-way screw terminals IN0 and IN1 using 2-core cable

WARNING: Do not apply any voltage to terminal IN1 as this will damage the CCS PCB.

NOTE: To promote increased energy saving a more advanced weather compensation control strategy is available from Thermoscreens. Using a heating curve, the discharge air temperature of the airstream coming from the air curtain is controlled against the outside air temperature. Visit the Thermoscreens website for details.

12. MULTIPLE AIR CURTAIN SYSTEMS

To Master/Slave two or more air curtains together, or if there are two air curtains in a vertical stack, the remote control is plugged into the first unit (the Master) and a RJ extension lead then connected from the Master to the Slave unit(s).

Horizontal application air curtains may be connected as indicated below. Thermoscreens 3m RJ extension leads are available and should be ordered separately.

For horizontal Master/Slave configuration an independent mains supply as per Table 1 must be supplied to each air curtain.

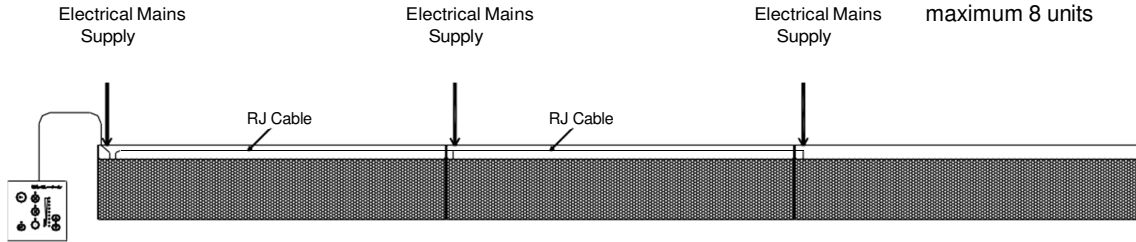

Fig 16

The maximum height for a vertical stack is 2.78m (1.5m + 1.0m vertical). An RJ extension lead and in-line RJ connector is supplied with vertical stack units.

Ensure all incoming electrical mains supply cables are suitable for the total power rating of the air curtain stack (see D2500).

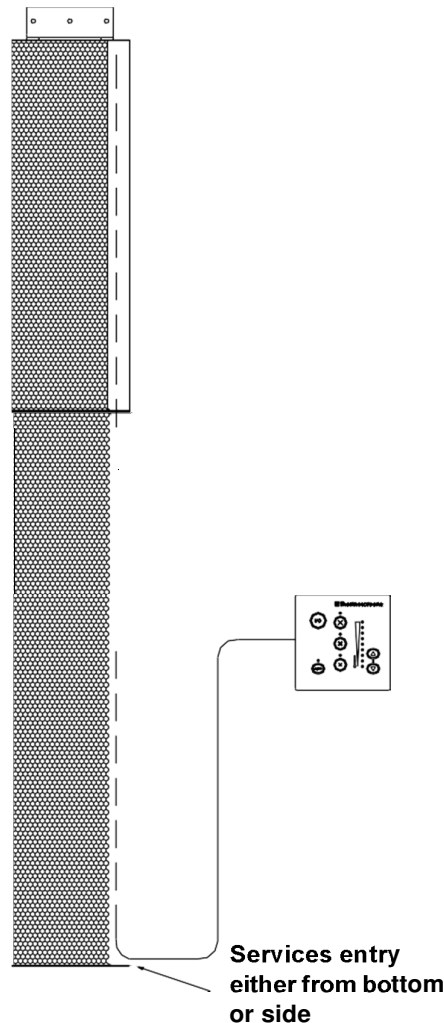

Fig 17

13. SYSTEM CONFIGURATION

13.1 Optional features

WARNING: Isolate and disconnect air curtain from the power source before making any changes.

DIP switches on the air curtain CCS PCB (see Fig 18) provide the following optional features, as explained below:

- Fan heat interlock
- Disable fan run-on
- Thermostat master (for master/slave installations)
- Weather compensation heat control (Summer/Winter)
- Door switch control

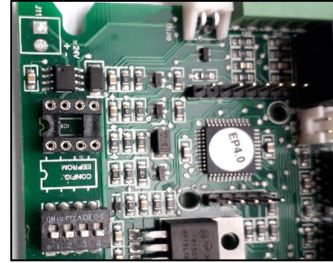

Fig 18

Feature	DIP setting	Default	Notes
<p>Fan heat interlock Allows fan speed to govern heat output on electric heated units.</p> <p>If low or medium fan speed is selected, a lower heat output results. High heat operates only on high fan speed.</p>	<p>DIP 1</p> <p>ON</p>	<p>ON</p> <p>Heat output is governed by fan speed.</p>	<p>This feature is only used with electric heated air curtains to limit very high air temperatures.</p> <p>Set DIP1 to OFF if unit is water heated or ambient.</p>
<p>Disable fan run-on The 2 minute fan run-on after switch off is enabled or disabled on electric heated air curtains.</p>	<p>DIP 2</p> <p>ON</p>	<p>OFF</p> <p>Fan run-on at medium speed enabled.</p>	<p>Must only be used for water heated or ambient air curtains. Each air curtain must have DIP2 set to ON for no fan run-on.</p>
<p>Thermostat master For master/slave installations. Only the air sensor in the thermostat master air curtain is used to measure air temperature.</p> <p>Set DIP 3 to ON in the air curtain that will be the master unit.</p>	<p>DIP 3</p> <p>ON</p>	<p>OFF</p> <p>Air curtains in master/slave systems all act independently.</p>	<p>Air sensor thermistors in all slave air curtains will be ignored.</p> <p>Stops some units blowing cold air and others blowing warm air in master/slave systems on larger doorways.</p>
<p>Weather compensation control <u>or</u> Door switch control</p> <p>Simple weather compensation control to save heating energy.</p> <p>or Door switch control.</p>	<p>DIP 4</p> <p>ON</p>	<p>OFF</p> <p>IN1 Weather compensation</p> <p>ON</p> <p>IN1 Door switch</p>	<p>See section 11.1 Remote Switch Contacts IN0 and IN1 for details</p> <p>Weather compensation control is the same as Summer/Winter control</p>
<p>NOTE: ■ — Black rectangle is moveable head of DIP switch.</p>			

NOTE: A range of advanced factory fitted and plug-in control options are available from Thermoscreens to enhance the performance of the CCS PCB controller inside the air curtain. These include advanced weather compensation control using a heating curve, outlet air temperature control, ECObus® BACnet/Modbus BMS control, modulating heater outputs and EEPROMs for non-standard control strategies. Visit the Thermoscreens website for details.

14. FAN SPEED SELECTION

Factory settings for the 3 fan speeds are shown in Table 5 below:

(refer also to wiring diagrams in Appendix 3)

Table 5

Fan Speed	Maximum air velocity at outlet grille (m/s)	Maximum air curtain mounting height (m)	Sound Pressure Level of air curtain [dB(A) at 3m]	Air Volume Flow Rate (m ³ /h) [for A]
HIGH (black wire)	11.0	3.5	PHVD1000 - 59 PHVD1500 - 60 PHVD2000 - 61	2050 3645 4145
MEDIUM (blue wire)	–	–	PHVD1000 - 57 PHVD1500 - 57 PHVD2000 - 59	1840 3455 3720
LOW (red wire)	–	–	PHVD1000 - 56 PHVD1500 - 53 PHVD2000 - 58	1720 3345 3480

Sound pressure levels dB(A) at 3m distance are for a single air curtain mounted at its maximum mounting height, operating in a room with average acoustic characteristics as defined in CIBSE Guide B5 (reverberation time 0.7s at 1kHz) and a room size equivalent to 8 air changes per hour (ac/h). Care needs to be taken when selecting air curtains for an installation as noise levels can be several dB higher if the mounting height is reduced, if the room is more 'live' (i.e. hard surfaces, no furnishings or absorbent materials), if the room is smaller than 8 ac/h equivalent or a combination of these factors. Noise levels will also increase if more than one air curtain is installed at the same doorway (e.g. +3dB(A) for 2 equal point sources: direct field).

15. REMOTE CONTROL OPERATION

15.1 Touch Controller

Please scan QR code and follow links to access the user guide and download App.

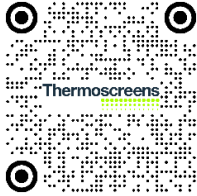

Use the Remote Control to



Home Speed Up Down

Controller connected via RJ communications lead to CCS PCB with Home, Speed, Up and Down touchpads below the LCD screen as detailed above.

On/Off

Press and hold Home touchpad for 2 seconds to turn air curtain ON or OFF.

NOTE: If an electric heated air curtain is heating when switched off the fan will run-on for approximately 2 minutes to dissipate excess heat.

Manual/Automatic

With Controller turned ON tap Home touchpad to switch between Automatic and Manual mode.

The screen displays either **A** for "Auto Mode" or **M** for "Manual Mode".

Heating level control

Manual mode



Select heating level and cycle between zero, half heat  and to full heat  with each short Up or Down touchpad press.

Automatic mode

Heat output is controlled automatically according to inlet air and the desired temperatures. The inlet air temperature is the upper temperature indication on the Controller adjacent to  on the LCD screen.

Fan speed

Short press Switch touchpad to switch and cycle fan speed:

- low 
- Medium 
- High 

Date and Time Settings

Configure Date and Time settings either via App or on Controller as below.

Turn Controller ON and hold Speed touchpad for 2 seconds

Follow instructions on LCD screen with:

- Tap Up touchpad to increase value
- Tap Down touchpad to decrease value
- Tap Speed touchpad to confirm values

16. COMMISSIONING THE SYSTEM

16.1 Verify system operation

To commission the system, verify the following conditions are met:

- All fans are working.
- Fans operate at Low, Medium and High speeds.
- There is no excessive mechanical noise coming from the fans.
- When heating is selected, the air stream from the discharge grille warms up across the whole length of the air curtain.
- When set to manual with fans set to high speed, heating increases as higher heat is selected.
- Warm air reaches across the doorway with door open or closed.
- For electric and water heated air curtains Controller operates correctly in both manual and auto modes.

16.2 Instruct customer and hand over

Before leaving site, hand over the installation to the customer/end user or their representative.

Explain that any person operating the air curtain must be given supervision and instruction by the person responsible for their safety, concerning the safe use of the unit and to understand any hazards involved. Children and those with reduced physical, sensory or mental capabilities should not operate the air curtain.

Recommend that the doorway should be closed whenever possible but that during times of high pedestrian use it will become an 'open doorway'. The air curtain then serves an essential purpose by saving energy and providing comfort to occupants.

Explain that the inlet grilles and air filters (if fitted) must be cleaned regularly and the unit serviced at schedule intervals – see section 19: Service & Maintenance.

NOTE: Leave these instructions with the customer/end user or their representative!!

17. SIGN OFF

Complete the following once commissioning is completed:

Installer signature		Customer signature	
Installer name		Customer name	
Installer company		Customer company	
Date		Date	

18. FAULT CONDITIONS

An overheat fault in electric heated units may cause the overheat safety cut-out(s) to operate.

Before resetting ensure there is adequate air flow from the air curtain and the unit has been commissioned as per section 16.

18.1 Touch Controller Reset Overheat Safety cut-out

This is indicated by flashing warning symbol on Touch Controller and a red status LED on the CCS PCB inside the air curtain.

To reset a overheat safety cut-out:

- Step 1** Switch off the electrical supply to the air curtain.
- Step 2** Allow time for the air curtain to cool down, typically 10 minutes.
- Step 3** Switch on the electrical supply to the air curtain.
- Step 4** If Controller is switched off, press and hold Home button for 2 seconds to turn Controller ON.
- Step 5** Press the Home touchpad on Controller 8 times.

Air curtain heaters will then operate and after 30 seconds the Controller warning symbol will disappear and status LED on CCS PCB flash green.

18.2 Fuses

In the event of an electrical fault internal electrical fuses may operate.

There are two internal fuses located on the CCS PCB inside the air curtain:

- Fuse 6.3A(T) supplies the fan motors within the air curtain
- Fuse 100mA(F) controls the circuitry of the CCS PCB

18.3 CCS PCB status indication

There is a status LED on the CCS PCB inside the air curtain (See LED shown on Wiring Diagrams in the Appendix).

This indicates the status of the CCS Controls as follows:

1. LED flashing green – operation normal
2. LED flashing red – low supply voltage, remote control not plugged in or RJ cable fault
3. LED permanently red – overheat safety cut-out(s) open circuit from an overheat situation (see Section 18: Fault Conditions for how to reset)

19. SERVICE & MAINTENANCE

WARNING: Failure to adequately maintain the unit and provide a suitable cleaning schedule will result in a loss of performance and reduced life expectancy of the air-curtain and possible overheating and fire risk with electric heated units.

19.1 Every week

NOTE: Weekly maintenance can be carried out by the Cleaner or Janitor from floor level.

Turn off the air curtain to prevent entry of dust then clean the face of the air inlet grilles using a vacuum cleaner with an extension tube and brush.

19.2 Every 3 months

WARNING: Before servicing, isolate and disconnect the air curtain from the electrical power.

WARNING: The following servicing and maintenance must be carried out by a competent electrician or a Thermoscreens appointed technician.

Clean and inspect the inside of the air curtain as follows:

- Step 1** Remove the back and inlet grille panels.
- Step 2** Clean and remove any build-up of dust and dirt within the air-curtain (back/inlet grille panels, electric heaters (if fitted), fan impellers, housings and motors) using a vacuum cleaner and soft brush.

NOTE: Build-up of dirt on fan impellers can cause vibration, noise and excessive wear on the motor bearings.

- Step 3** Check within the unit to ensure all electrical connections and crimped terminals are tight and that all cables are in good condition.

Refit air inlet grilles after servicing. Reconnect electrical supply and test to ensure correct operation (see Section 16: Commissioning).

20. WARRANTY

All units are covered by a two year warranty.

Failure to adequately maintain the unit may void the warranty. If any problems are encountered, please contact your installer/supplier.

Failing this please contact the Thermoscreens warranty department.

Care has been taken in compiling these instructions to ensure they are correct. Thermoscreens disclaims all liability for damage resulting from any inaccuracies and/or deficiencies in this documentation. Thermoscreens retain the right to change the specifications stated in these instructions.

Thermoscreens
St. Mary's Road Nuneaton
Warwickshire England
CV11 5AU

Email: sales@thermoscreens.com
Tel: + 44 (0) 24 7638 4646
Fax: + 44 (0) 24 7638 8578
www.thermoscreens.com

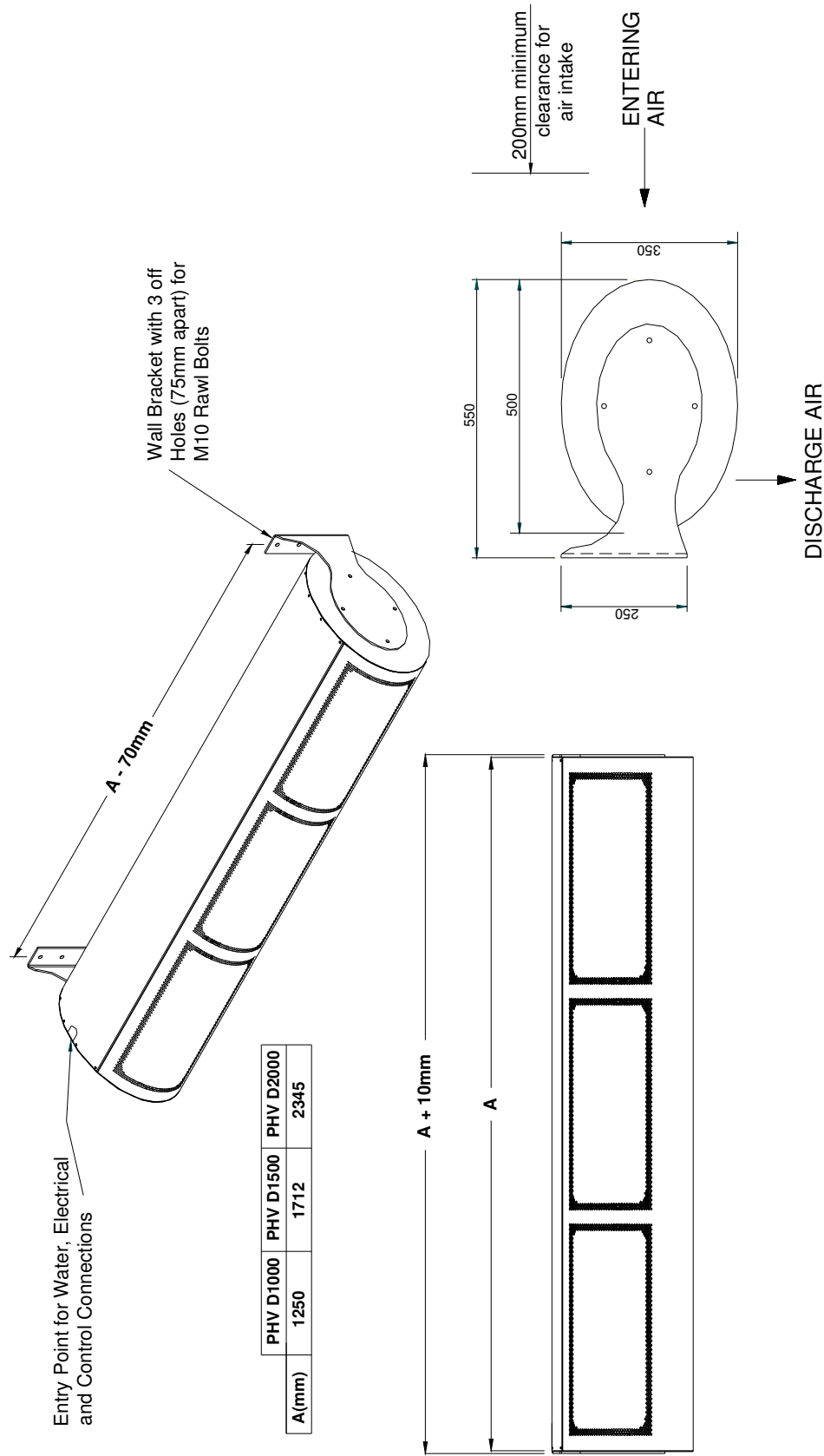

A(mm)	PHV D1000	PHV D1500	PHV D2000
	1250	1712	2345

APPENDIX 1A — DIMENSIONS OF HORIZONTAL AIR CURTAIN (WALL MOUNTED)

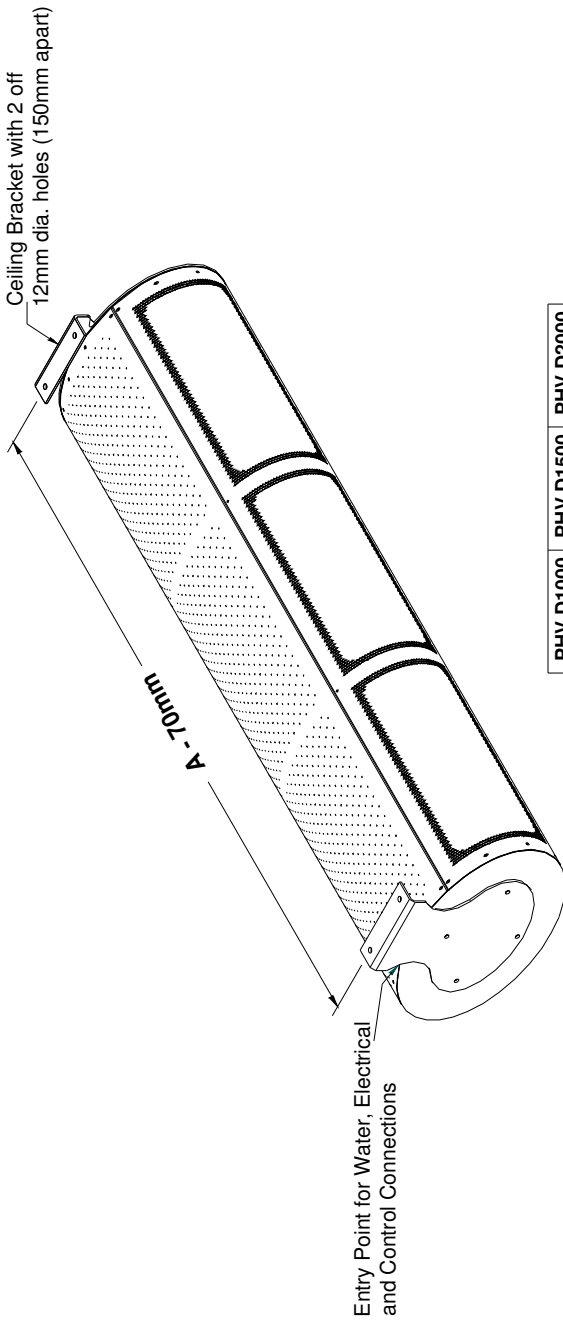

A(mm)	PHV D1000	PHV D1500	PHV D2000
	1250	1712	2345

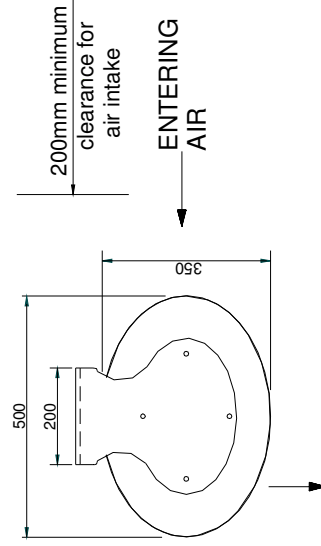
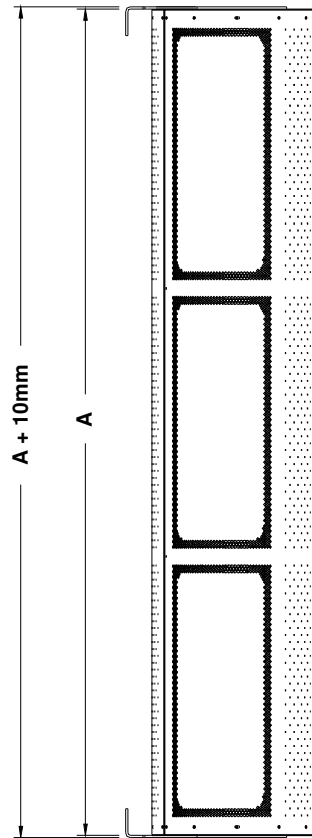

DISCHARGE AIR

APPENDIX 1B — DIMENSIONS OF HORIZONTAL AIR CURTAIN (CEILING MOUNTED)

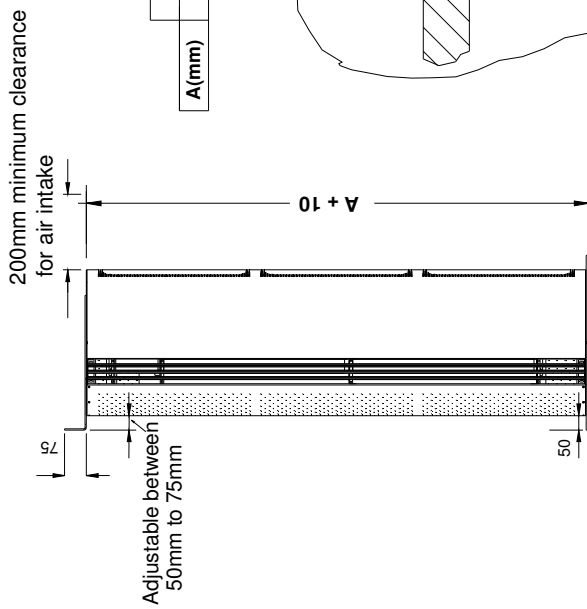

A (mm)	PHV D1500V	PHV D2000V	PHV D2500V	PHV D3000V
	1712	2345	2962	3609

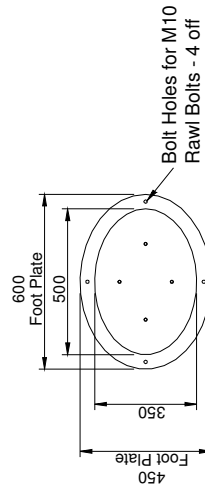
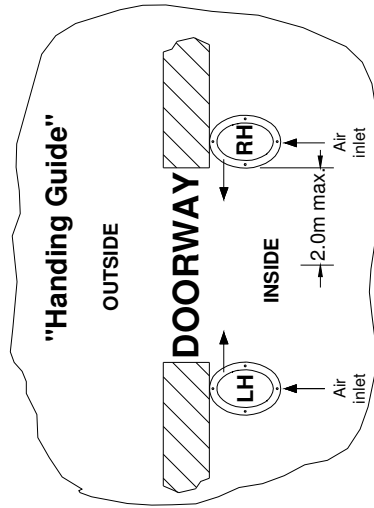
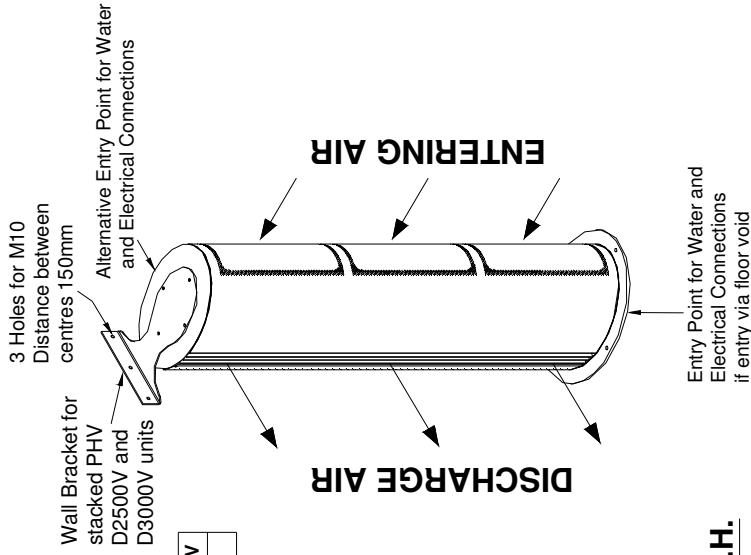

As Drawn for R.H.
Opposite Hand for L.H.

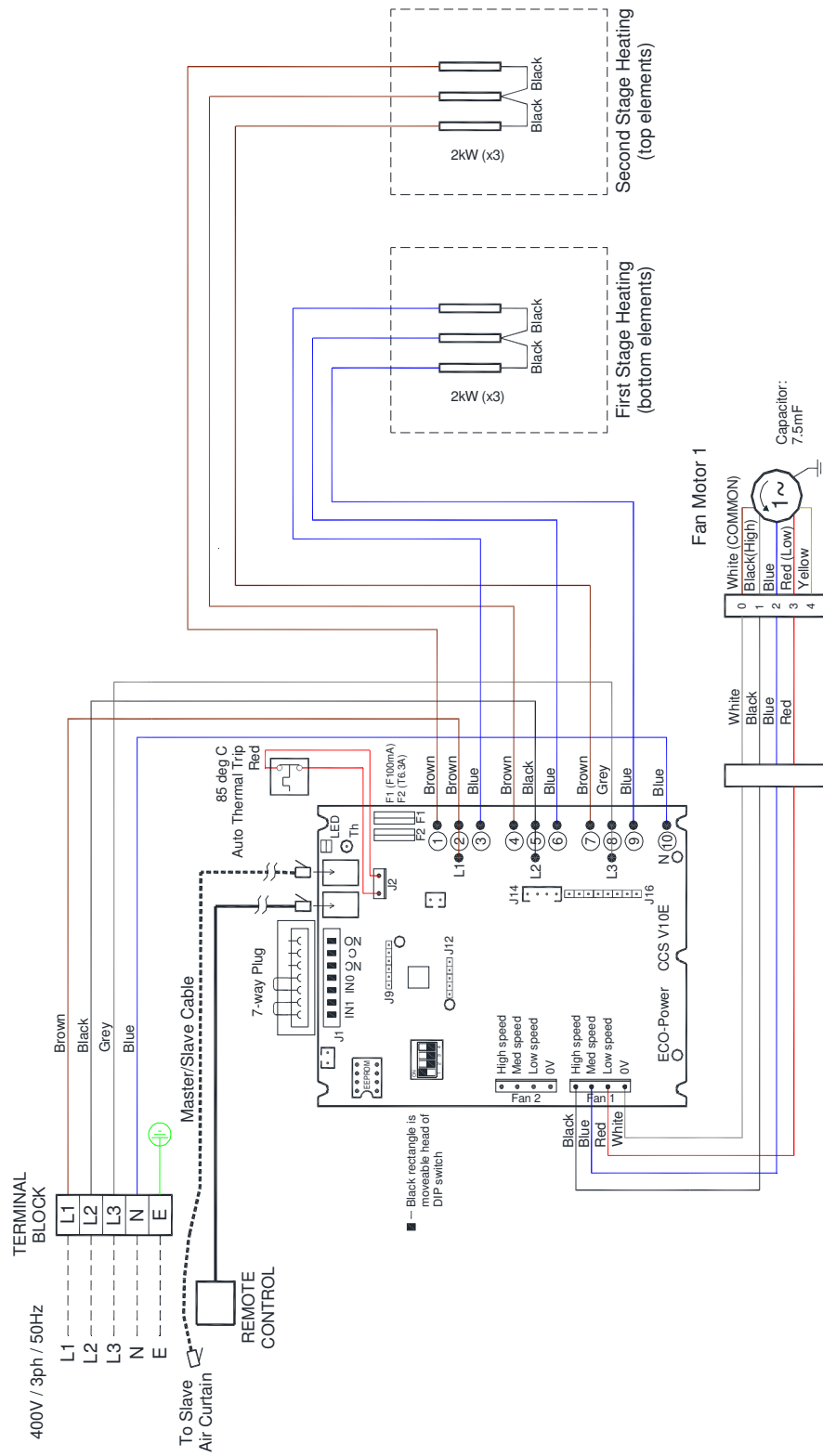

APPENDIX 3A — WIRING DIAGRAM PHVD1000E and PHVD1000E V*
 * used as top air curtain for vertical stacking only

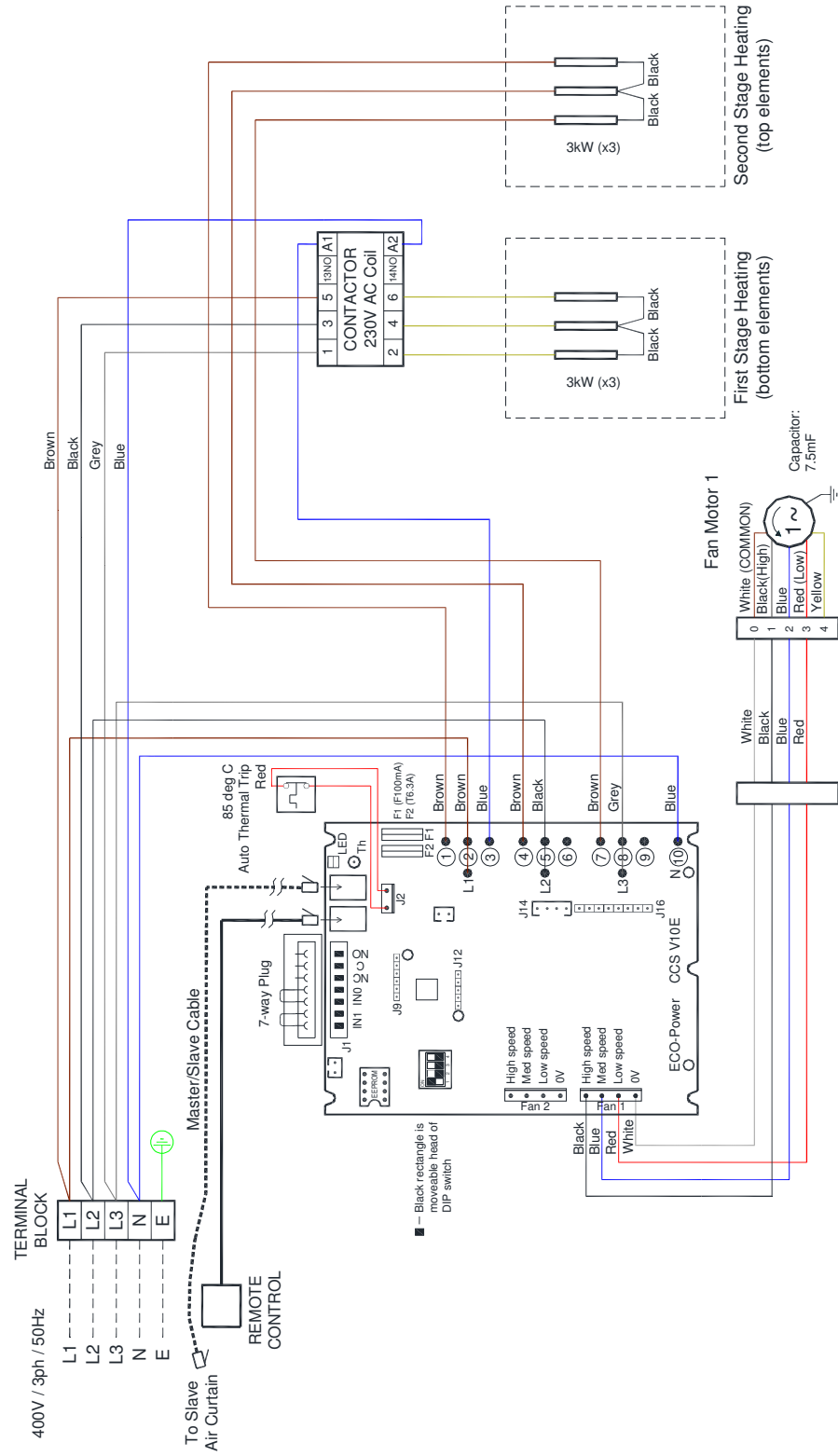

APPENDIX 3B — WIRING DIAGRAM PHVD1500E and PHVD1500E V

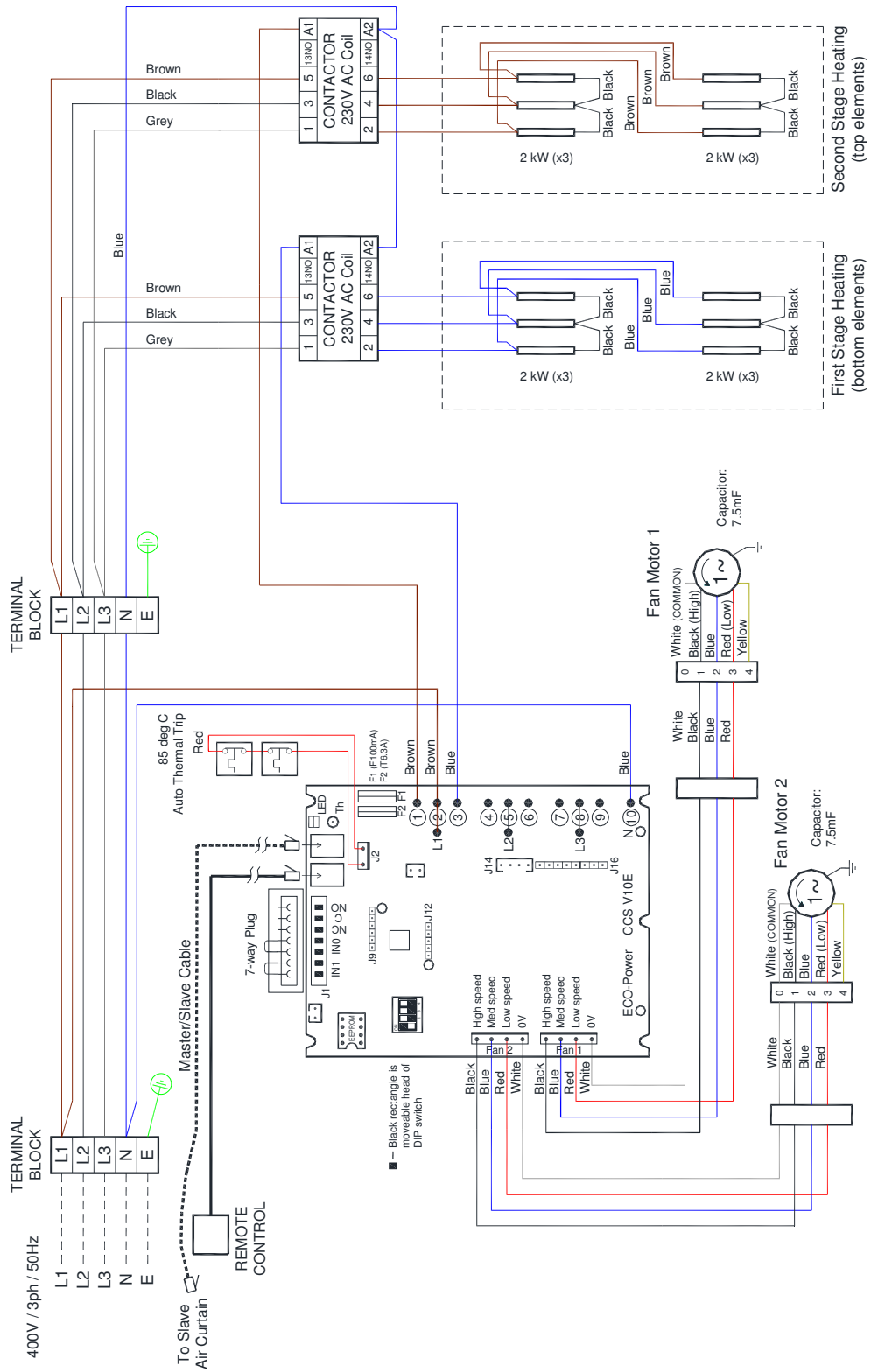

APPENDIX 3C — WIRING DIAGRAM PHVD2000E and PHVD2000E V

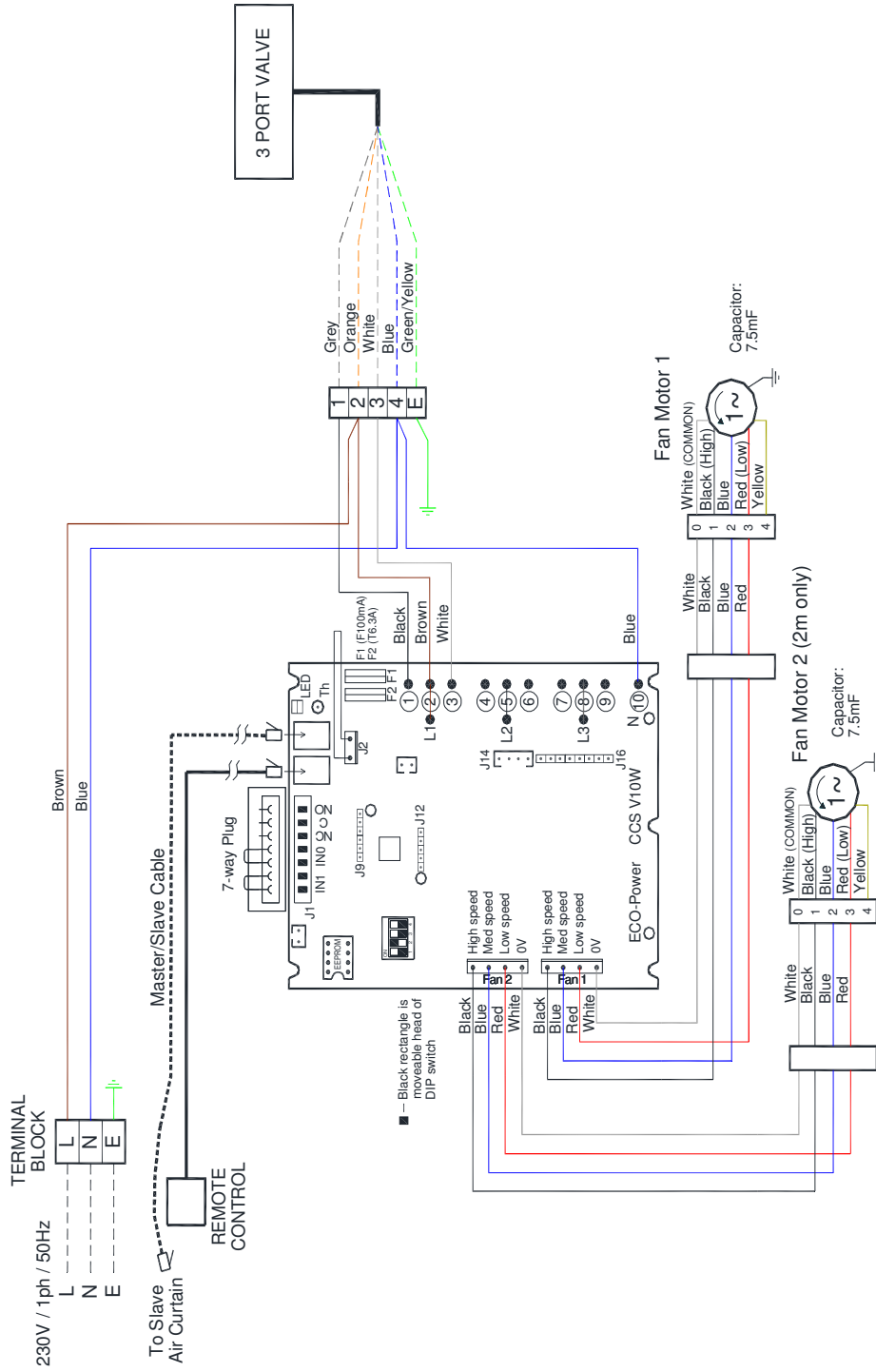

APPENDIX 3D — WIRING DIAGRAM PHVD1000W, PHVD1500W, PHVD2000W, PHVD1000W V*, PHVD1500W V and PHVD2000W V
 * used as top air curtain for vertical stacking only

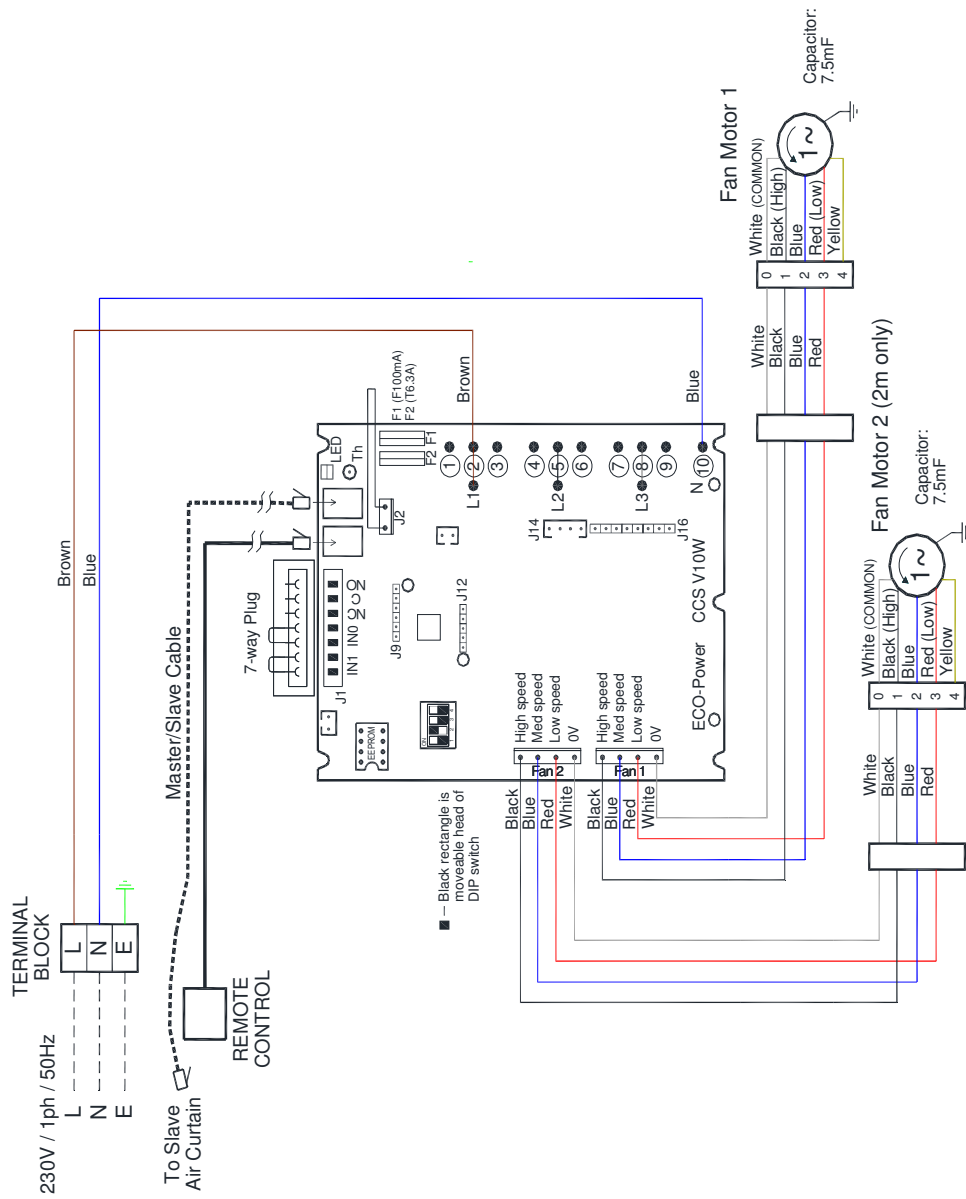

APPENDIX 3E — WIRING DIAGRAM PHVD1000A, PHVD1500A, PHVD2000A V, PHVD2000A V* used as top air curtain for vertical stacking only

21. DECLARATION OF CONFORMITY

Carver International Ltd T/A Thermoscreens
St Mary's Road Nuneaton
Warwickshire
CV11 5AU
United Kingdom
Telephone: +44 (0)24 7638 4646 www.thermoscreens.com



EC DECLARATION OF CONFORMITY
as defined by the EC Council Directive on Machinery 2006/42/EC,
the Low Voltage Directive 2014/35/EC, Electromagnetic Compatibility Directive 2014/30/EC, the
Energy related Products Directive 2009/125/EC

Herewith we declare that the air movement equipment designated below, on the basis of its design and construction in the form brought onto the market by us in accordance with the relevant safety, health and performance requirements of the Machinery. If alterations are made to the machinery without prior consultations with us, this declaration becomes invalid. This declaration of conformity is issued under the sole responsibility of the manufacturer.

Designation of Equipment: AIR CURTAINS

Series Type: PHVD1000A; PHVD1000E; PHVD1000W; PHVD1500A; PHVD1500E;
PHVD1500W; PHVD2000A; PHVD2000E; PHVD2000W; PHVD1500A V;
PHVD1500E V; PHVD1500W V; PHVD2000A V; PHVD2000E V; PHVD2000W V

Relevant EC Council Directives: the Machinery Directive (2006/42/EC)
the Low Voltage Directive (2014/35/EU)
the Electromagnetic Compatibility Directive (2014/30/EU)
the Pressure Equipment Directive (97/23/EC)
the EcoDesign Products Directive (2009/125/EC; Comm. Reg. 327/2011)
the Restriction of Hazardous Substances Directive (2017/2102)

The object of the declaration described above is in conformity with the relevant Union harmonisation legislation:

Machinery -	BS EN ISO 12100:2010, BS EN ISO 13857:2008
LVD -	EN 60335-1:2012+A11:2014, EN 60335-2-30:2009+A11:2012
EMC -	EN 61000-6-1:2007, EN 61000-6-3:2007+A1:2011, EN 61000-3-2:2014 + A2:2009, EN 61000-3-3:2013
PED -	EN 13133:2000, EN 13134:2000
ErP -	Commission Regulation (EU) No. 327/2011, ISO 5801:2007, ISO 12759:2010
RoHS -	EN 63000:2018

Basis of Self Attestation: Quality Assurance to BS EN ISO 9001: 2008
B.S.I. Registered Firm Certificate Number FM 85224 SGS
Test Report ELS150049/2/R/DC/11;
SGS Test Report EMC150049/1
CE Marking Association Test Report 6799 and 6800

Responsible Person: Carole Keane, Group Marketing Director.

Date: 1st April 2020

Signed:

A handwritten signature in black ink that reads "Carole Keane". The signature is written in a cursive style with a large initial 'C'.

