

PHVX Series

Recessed mounted

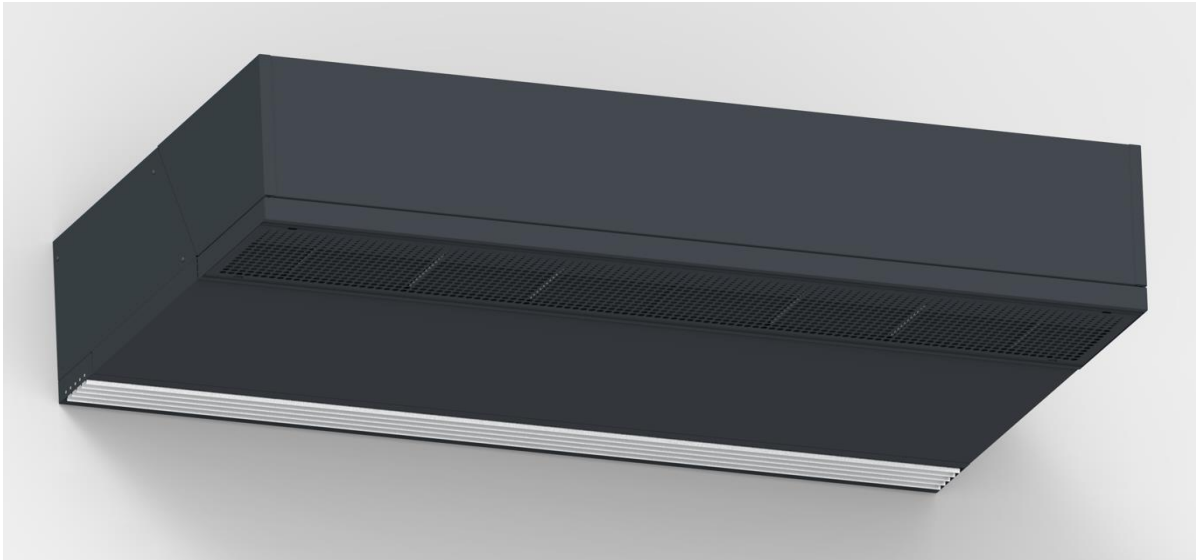

INSTALLATION, OPERATION & MAINTAINANCE ORIGINAL INSTRUCTIONS

N. America
English

IMPORTANT INFORMATION

Electrical Supply and Wiring to the Air Curtain

All electrical wiring and connections MUST be carried out by a competent qualified electrician in accordance with the latest edition of IET wiring regulations and local statutory regulations if applicable.

- A 1 phase or 3 phase local isolator having a contact separation of at least 3mm on all poles must be fitted in the electrical supply to the air curtain and located in an accessible position adjacent to the unit.
- The appliance must be connected by cables having an appropriate heat resistant temperature rating.
- All supply cables, circuit breakers and other electrical installation equipment must be correctly sized for the air curtain model being installed – refer to Technical Specifications section.
- Models operating on a 3 phase -208V will require two 3 phase supplies. Supply details are listed in the Technical Specifications section.
- See Wiring Diagrams for connecting electrical supply/s and control cables to the air curtain. The air curtain must be earthed.

CAUTION – Some parts of this product can become very hot and cause burns. Particular attention must be given where children and vulnerable people are present

WARRANTY

All units are covered by a two-year warranty. Failure to adequately maintain the unit may void the warranty. If any problems are encountered, please contact your installer/supplier. Failing this, please, contact the Thermoscreens warranty department. Care has been taken in compiling these instructions to ensure they are correct. Thermoscreens disclaims all liability for damage resulting from any inaccuracies and/or deficiencies in this documentation. Thermoscreens Ltd. retain the right to change the specifications stated in these instructions.

Thermoscreens
1210 Balmoral Rd.
Cambridge, ON N1T 1A5
Canada

Email: warranty@carver-na.com
Tel: 1-877-445-3739
www.thermoscreens.ca

Established in the 1960s, Thermoscreens is a leading air curtain manufacturer that exports to over 60 countries worldwide. As with all our products, the PHVX range of air curtains is designed with energy efficiency in mind. The units are designed to be recessed mounted inside a building and located horizontally over a doorway. They must not be installed on the outside of a building or built into a cabinet or recessed in any way.

Please complete the following details for your reference:

Date of Purchase:
Place of Purchase:
Serial Number:

Proof of purchase is required to make a claim under warranty.

SIGN OFF

Complete the following once commissioning is completed:

Installer signature		Customer signature	
Installer name		Customer name	
Installer company		Customer company	
Date		Date	

Instruct customer and hand over

Before leaving site, hand over the installation to the customer/end user or their representative.

Explain that any person operating the air curtain must be given supervision and instruction by the person responsible for their safety, concerning the safe use of the unit and to understand any hazards involved. This appliance can be used by children aged from 8 years and above and persons with reduced physical, sensory or mental capabilities or lack of experience and knowledge if they have been given supervision or instruction concerning use of the appliance in a safe way and understand the hazards involved. Children shall not play with the appliance. Cleaning and user maintenance shall not be made by children without supervision.

Recommend that the doorway should be closed whenever possible but that during times of high pedestrian use it will become an 'open doorway'. The air curtain then serves an essential purpose by saving energy and providing comfort to occupants.

Explain that the air inlet surface must be cleaned regularly and the unit serviced at schedule intervals – see section: "*Service & Maintenance*".

NOTE: Leave these instructions with the customer/end user or their representative

DELIVERY CONTENTS

The following items are supplied in the box at delivery. Any missing or damaged parts should be reported to the place of purchase:

- PHVX Recessed Mounted Air Curtain
- Ecopower Remote Control (Supplied with 6m [20ft] RJ Control Cable)
- 3-port Control Valve (For Water Heated Units)
- Wall Brackets (Optional)

TRANSPORT, STORAGE AND DISPOSAL

The product must be stored in a dark, dry, frost free and well ventilated place out of the reach of children. Storage temperatures should be within those specified in the Technical Specifications section. The original packaging should be used for long term storage.

Prior to transporting the product, it should be removed and stowed safely so as to not incur damage. The original packaging should be used wherever possible and the product should be protected from any significant temperatures, moisture or vibration.

During installation, maintenance and decommissioning the air curtain it will be necessary to move the product.

This product will offer many years of service when used and maintained in line with these instructions. When the product does need to be disposed of, please recycle the product where facilities exist. Waste electrical products should not be disposed of with household waste.

INSTALLATION

The air curtain is designed to be located horizontally over a doorway. It must not be installed outside of the building. The recessed model is designed for installation above a false ceiling.

Location

Mount the air curtain above and as close to the doorway as possible, with:

- the discharge grille not more than 3.7 m [12ft 2 in] or less than 1.8m [6ft] above floor level.
- at least 100 mm [4 in] clearance (air gap) above the air curtain in the ceiling void, see Fig 1
- at least 225 mm [9 in] clearance above the air curtain for 3ft long units, see Fig 2.

Beware of doorway top edges, structural beams, door opening/closure devices, etc., which may interfere with the air stream and affect the location of the unit.

NOTE: For the air curtain to work well the width of the open doorway should be less than the length 'A' of the air curtain, see Appendix 1. Additional units can be installed side by side to cover larger openings.

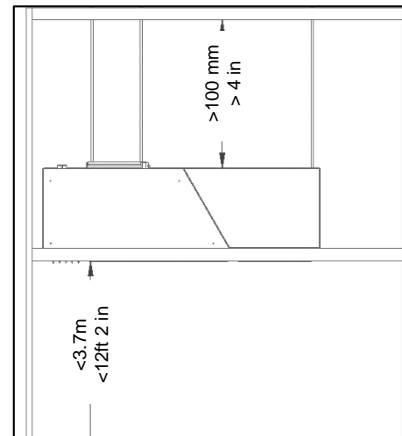

Figure 1

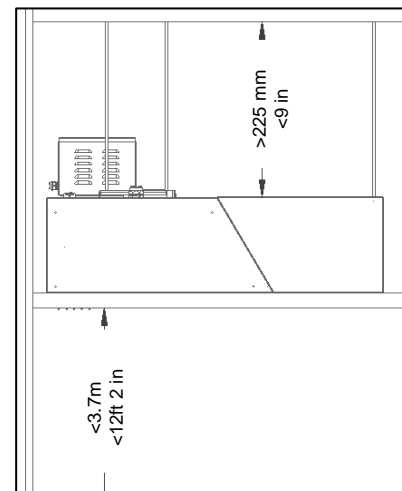

Figure 2

Wall Fixing (using optional wall brackets)

NOTE: Use suitable wall fixing bolts (not supplied) to fix the unit to the wall, taking into account the type of wall and the weight of the unit (see section: "Technical Specifications").

- Step 1** Drill and bolt all wall brackets to the wall as shown in Fig 3a, using suitable fixings referring to Appendix 1 for correct position.
- Step 2** Raise the unit up from below using suitable lifting means and secure to the wall brackets using the supplied M6 bolts (Fig 3b).
- Step 3** Tighten all fixing bolts until the air curtain is safely secured to the wall.

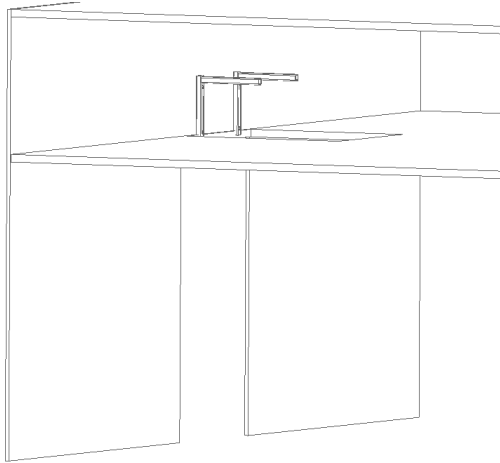

Figure 3a

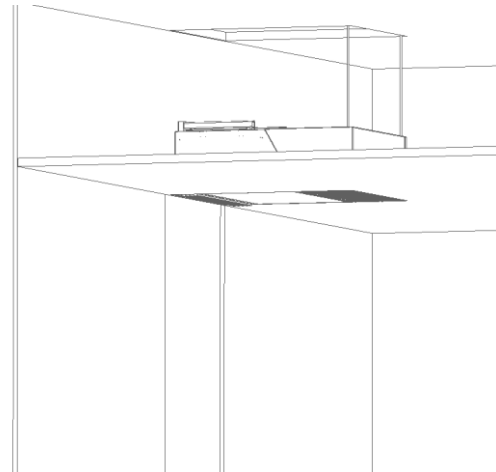

Fig 3b

Ceiling Suspension

Suspend the unit from the ceiling as follows:

Step 1. Fix four threaded rods M8 or 5/16-18 (not supplied) according to the dimensions in the table 1 below. Make sure the threaded rods are perpendicular.

Note: Units of type PHVX-5ft and PHVX-6ft have three suspension brackets.

Fix six threaded rods for that type.

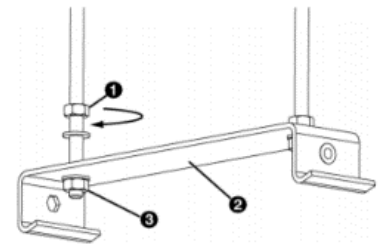
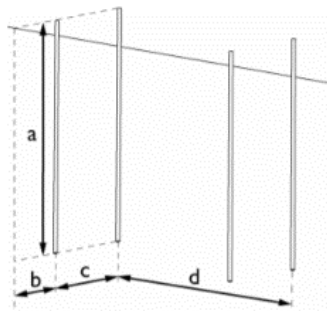

Figure 4

Table 1



Size	Type	Dimensions
a	All models	As needed
b	All models	200 mm // 7.9 in
c	All models	200 mm // 7.9 in
d	3ft 4ft 5ft 6ft	450 mm // 1ft 6 in 750 mm// 2ft 6 in 2 x (500 mm// 1ft 8 in) 2 x (750 mm // 2 ft 6 in)

Step 2. Apply a lock nut (fig 4, element 1) to each threaded rod.

Step 3. Fit drop rods through the mounting holes found in the suspension brackets (fig 4), and secure each drop rod by fitting the nuts on the underside of the suspension bracket (fig 4, element 3).

Step 4. Make sure the suspension brackets are suspended horizontally and flush.

Step 5. Secure each suspension bracket by tightening the lock nut

Step 6. Mount the inlet case to the unit. Hook the inlet case onto the upper side of the unit and then screw flange [1] of the inlet case to the unit.

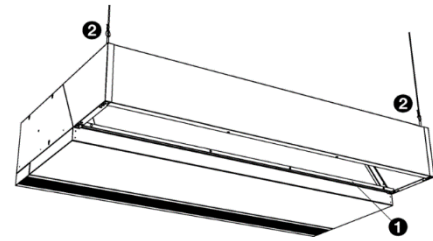

Step 7. Fix the angle points [2] of the inlet case to the ceiling. To do so, use the supplied screw eyes or four threaded rods, M6

Step 8. Screw the inlet frame to the inlet plenum. Use 6 off M6 hex screws.

Step 9. Put the grille back into its frame. Push the two hinges in and align with the fixing points in the frame. Repeat this operation with the two hinges at the bottom of the grille

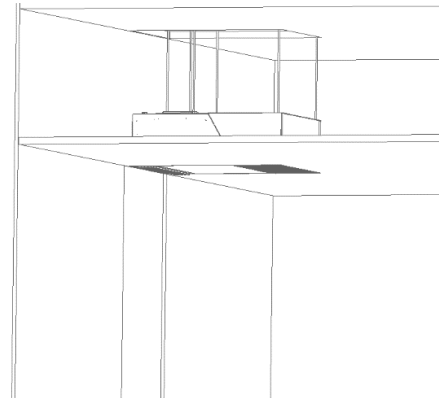

Note: Lock nut, plain nuts and washers are not supplied in the box.

Figure 5

Warning:

If you do not fix the inlet case to the ceiling, the unit may tip over and fall out of the suspension rails.

WARNING: It is the sole responsibility of the installer to ensure that the fixing locations and suspension system used are suitable for the air curtain being installed.

LPHW Models

For LPHW models ensure that water isolation valves are fitted in the flow and return pipework adjacent to the air curtain and connected correctly as shown in the diagram in Appendix 1.

For the design of the water pipework system and pump, water flow rates and pressure drops for maximum heat output of the air curtain are given in Table 2 below.

Table 2

Air Curtain	Maximum heating capacity (kW [MBH])	Airflow (m ³ /h [cfm])	Water Flow Rate (l/h at 82/71°C [Gall/h at 180/160 °F])	Water Pressure Drop (kPa [psi])	Air off Temperature (°C [°F])
PHVX3W, 2-row	18.9 [64.5]	2600 [1530]	1515 [400]	5.3 [0.8]	42.7 [108.9]
PHVX4W, 2-row	24.7 [84.3]	3100 [1824]	1976 [522]	10.6 [1.5]	44.7 [112.5]
PHVX5W, 2-row	34.7 [118.4]	4500 [2649]	2772 [732]	23.3 [3.4]	43.9 [111.0]
PHVX6W, 2-row	41.4 [141.3]	5200 [3061]	3312 [875]	37.4 [5.4]	44.7 [112.5]

Maximum heating capacity denotes the maximum heating capacity with 82/71°C [180/160°F] flow & return water temperatures. The unit discharges air at its maximum temperature (Air off Temperature).

Calculations have been made using the following conditions:

EAT= 21°C [70°F] and 50 % humidity.

NOTE: Water Pressure Drop is across the flow and return pipework to the air curtain and includes for the coil fitted inside the unit and the valve fitted in the heating pipework to the unit.

The installer must connect the 3-port valve in the heating pipework as shown in Figure 6 below:

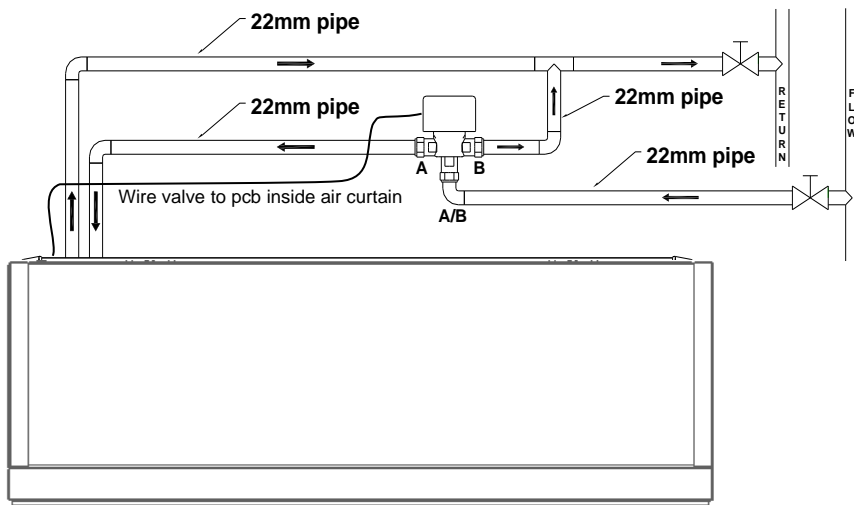

Fig 6

ACCESS FOR ELECTRICAL CONNECTION

Power Supply Connection

The unit is designed to have all electrical connections made by removing the inlet plenum, inlet grille and the inspection panel. After removing both, run a suitable sized power supply cable into the unit via the cable gland at the back of the unit and connect the cables to the terminal connectors to L1, L2, Earth for single phase connections and to L1, L2, L3 and Earth.

Wire the product up accordingly to the site connections in Appendix 2

Note: For 5ft and 6ft 3 phase 208V electric units, installer will need to run two 3ph-208V power supplies cables to the unit. In those cases the connections are made to connectors L1, L2, L3, Earth, L1, L2, L3.

COMMISSIONING THE SYSTEM

Verify system operation

To commission the system, verify the following conditions are met:

- All fans are working.
- Fans operate at Low, Medium and High speeds.
- There is no excessive mechanical noise coming from the fans.
- When heating is selected, the air stream from the discharge grille warms up across the whole length of the air curtain.
- When set to manual with fans set to high speed, heating increases as higher heat is selected.
- Warm air reaches across the doorway with door open or closed.
- Ecopower Remote Control operates correctly in both manual and auto modes.

EXTERNAL CONTROLS

Remote switch contacts IN0, IN1

Terminals IN0 and IN1 on the Ecopower PCB inside the air curtain can be used to provide different control strategies using remote volt-free contacts (see Fig 7). This could be to provide remote On/Off from a timer or BMS Digital/Output contact, to work with a door switch or for simple weather compensation control to disable heating when outdoor air temperatures become warmer. Table 3 describes the different functions:

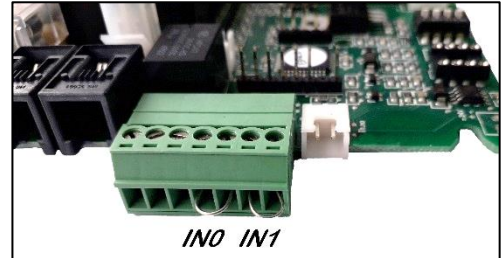







Fig 7

Table 3a

Function	IN0		Notes
			
Remote On/Off (INHIBIT) or Door Switch Control	Unit operates normally in MANUAL Mode or AUTO Mode from the Remote Control Door Open	Unit switches off after 15s, with fan run-on at Medium fan speed if DIP 2 = OFF Door Closed	Use the Remote Control to set up unit and then hide it away if required. * On/Off is then done via IN0 using a remote volt-free contact.

The below functions for IN1 will only work with IN0 in a closed state ():

Table 3b

Function	IN1		DIP 4	Notes
				
Boost Heater Control	After 30s the heating is disabled and the fan goes to low speed	Unit operates normally in MANUAL Mode or AUTO Mode from the Remote Control	ON	Open Circuit:-  Normal Control Closed Circuit:-  Heating Off Low Fan Speed
Summer Winter (Thermostatic Control)	Unit operates normally in MANUAL Mode or AUTO Mode from the Remote Control <i>COLD DAY</i>	Heating is disabled straight away, Fan speeds operate normally from the Remote Control <i>WARM DAY</i>	OFF	Simple weather compensation control using an outdoor air thermostat with volt free contacts (see Section "Weather compensation control")

NOTE: Wire volt-free, remote switch contacts to 2-way screw terminals IN0 and IN1 using 2-core cable.

WARNING: Do not apply any voltage to terminals IN0 and IN1 as this will damage the Ecopower PCB inside the air curtain.

*** NOTE:** The Ecopower Remote Control must stay plugged-in for the air curtain to keep working. An optional plug-in EEPROM is available from Thermoscreens so the Remote Control can be unplugged and the air curtain stay working. Visit the Thermoscreens website for details.

Overheat safety cut-out indication

For electric heated air curtains the Ecopower PCB includes a fault indication signal for if the overheat safety cut-out on the electric heater operates.

Volt free changeover contacts (6A 250VAC 30VDC) can be wired via the 3-way screw terminal “HEALTHY” (see Fig 8).

Refer to Section “Overheat Safety cut out, for how to reset a overheat safety cut-out situation.

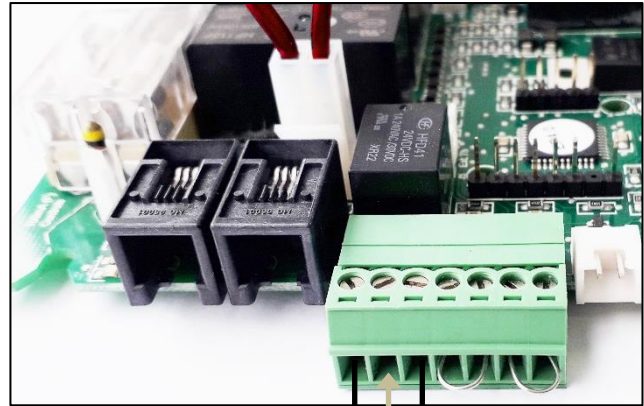

Fig 8

NO
HEALTHY
NC
ALARM!
C

Weather compensation control

To save heating energy on warmer days a simple weather compensation (Summer/Winter) heat control strategy can be used. Fit an outdoor air thermostat with volt-free contacts (supplied by the installer) to a north facing wall.

Use a 2-core cable to connect the outdoor air thermostat to 2-way terminal IN1 on the Ecopower PCB (see Fig 9)

On the Ecopower PCB, set DIP 4 to OFF as per Table 4, (see Section “Remote switch contacts IN0, IN1”).

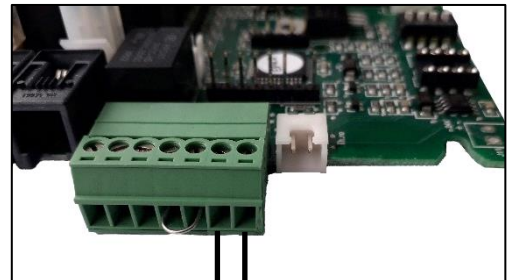

Fig 9

Switch Contact Closed = Heating Enabled (cold day)
Switch Contact Open = Heating Disabled (warm day)



WARNING: Do not apply any voltage to terminal IN1 as this will damage the Ecopower PCB.

NOTE: To promote increased energy saving a more advanced weather compensation control strategy is available from Thermoscreens. Using a heating curve, the discharge air temperature of the airstream coming from the air curtain is controlled against the outside air temperature. Visit the Thermoscreens website for details.

MULTIPLE AIR CURTAIN SYSTEMS

For master/slave control, plug and connect units together with Thermoscreen RJ extension cables (not supplied). Each air curtain must have its own electrical supply.

SYSTEM CONFIGURATION

Optional features

WARNING: Isolate and disconnect air curtain from the power source before making any changes.

DIP switches on the air curtain Ecopower PCB (see Fig 10) provide the following optional features, as explained below:

- Fan heat interlock
- Disable fan run-on
- Thermostat master (for master/slave installations)
- Weather compensation heat control (Summer/Winter)
- Door switch control

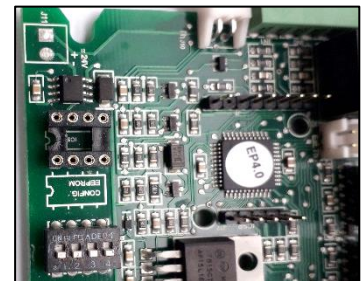
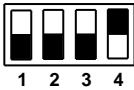

Fig 10

Feature	DIP setting	Default	Notes
<p>Fan heat interlock Allows fan speed to govern heat output on electric heated units.</p> <p>If low or medium fan speed is selected, a lower heat output results. High heat operates only on high fan speed.</p>	<p>DIP 1</p> <p>ON</p> <p>1 2 3 4</p>	<p>ON</p> <p>Heat output is governed by fan speed.</p>	<p>This feature is only used with electric heated air curtains to limit very high air temperatures.</p> <p>Set DIP1 to OFF if unit is water heated or ambient.</p>
<p>Disable fan run-on The 2-minute fan run-on after switch off is enabled or disabled on electric heated air curtains.</p>	<p>DIP 2</p> <p>ON</p> <p>1 2 3 4</p>	<p>OFF</p> <p>Fan run-on at medium speed enabled.</p>	<p>Must only be used for water heated or ambient air curtains. Each air curtain must have DIP2 set to ON for no fan run-on.</p>
<p>Thermostat master For master/slave installations. Only the air sensor in the thermostat master air curtain is used to measure air temperature.</p> <p>Set DIP 3 to ON in the air curtain that will be the master unit.</p>	<p>DIP 3</p> <p>ON</p> <p>1 2 3 4</p>	<p>OFF</p> <p>Air curtains in master/slave systems all act independently.</p>	<p>Air sensor thermistors in all slave air curtains will be ignored.</p> <p>Stops some units blowing cold air and others blowing warm air in master/slave systems on larger doorways.</p>

<p>Weather compensation control or Door switch control</p> <p>Simple weather compensation control to save heating energy.</p> <p>or</p> <p>Door switch control.</p>	<p>DIP 4</p> <p>ON</p>  <p>1 2 3 4</p>	<p>OFF</p> <p>IN1 Weather compensation</p> <p>ON</p> <p>IN1 Door switch</p>	<p>See section “Remote Switch Contacts IN0 and IN1” for details</p> <p>Weather compensation control is the same as Summer/Winter control</p>
---	--	---	--

NOTE: ■ — Black rectangle is moveable head of DIP switch.

NOTE: A range of advanced factory fitted and plug-in control options are available from Thermoscreens to enhance the performance of the Ecopower PCB controller inside the air curtain. These include advanced weather compensation control using a heating curve, outlet air temperature control, ECObus® Modbus BMS control, modulating heater outputs and EEPROMs for non-standard control strategies. Visit the Thermoscreens website for details.

USING THE SYSTEM

Basic (Wall Controller) Operation

The air curtain can be operated using the wall controller:

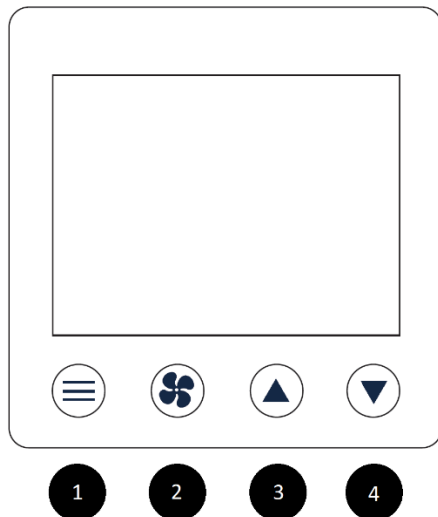

To switch on/off the air curtain:

- Press and hold button 1 for 5 seconds

To change modes:

- Press button 1

To change fan speeds:

- Press 2 to cycle between low, medium and high speed

To change heating levels:

- Press button 3 to increase the heating level
- Press button 4 to decrease the heating level

Wifi Operation

This air curtain can be operated remotely via an app. The app gives additional functionality such as scheduled start/stop, keypad locking and remote diagnostic readouts.

Setting up Wifi connectivity

1. Download and install the Thermoscreens air curtain app from the Apple App Store or Google Play Store
2. Follow on screen instructions to link the device to your app.

Additional Features

Please refer to the in app help manual on how to use the additional features in the app.

FAULT CONDITIONS

Overheat Safety cut-out

An overheat fault in electric heated units may cause the overheat safety cut-out(s) to operate.

This is indicated by flashing LEDs on the Remote Control and a red status LED on the Ecopower PCB inside the air curtain.

Before resetting ensure there is adequate air flow from the air curtain and the unit has been commissioned as per section “COMMISSIONING THE SYSTEM”.

To reset a overheat safety cut-out:

- Step 1** Switch off the electrical supply to the air curtain.
- Step 2** Allow time for the air curtain to cool down, typically 10 minutes.
- Step 3** Switch on the electrical supply to the air curtain.
- Step 4** Press the Auto button on the Ecopower remote control 4 times.

Air curtain heaters will then operate and after 30 seconds the LEDs on the remote control will stop flashing and the status LED on the Ecopower PCB in the air curtain will flash green.

Fuses

In the event of an electrical fault internal electrical fuses may operate.

There are two internal fuses located on the Ecopower PCB inside the air curtain:

- Fuse 6.3A(T) supplies the fan motors within the air curtain
- Fuse 100mA(F) controls the circuitry of the Ecopower PCB

Additionally, there are two fuses at the supply end with rates depending on the size of the unit (see wiring diagram for further information).

<p>WARNING: It is the sole responsibility of the installer to ensure that the fuses replaced are the same type and rating as the ones provided. Fuses must be of the type “20mm x 5mm Glass Fuse Slow Blow/Time Delay/Lag” with a current rating as described in wiring diagrams in the appendix.</p>
--

Ecopower PCB status indication

There is a status LED on the Ecopower PCB inside the air curtain (See LED shown on Wiring Diagrams in the Appendix).

This indicates the status of the Ecopower Control system as follows:

1. LED flashing green – operation normal.
2. LED flashing red – low supply voltage, remote control not plugged in or RJ cable fault.
3. LED permanently red – overheat safety cut-out(s) open circuit from an overheat situation (see Section: Fault Conditions – Overheat safety cut-out for how to reset)

SERVICE & MAINTENANCE

WARNING: Failure to adequately maintain the unit and provide a suitable cleaning schedule will result in a loss of performance and reduced life expectancy of the air-curtain and possible overheating and fire risk with electric heated units.

Every week

NOTE: Weekly maintenance can be carried out by the Cleaner or Janitor from floor level.

Turn off the air curtain to prevent entry of dust then clean the face of the air inlet plenum and the inside of the perforations using a vacuum cleaner with an extension tube and brush.

Every 3 months

WARNING: Before servicing, isolate and disconnect the air curtain from the electrical power.

WARNING: The following servicing and maintenance must be carried out by a competent electrician or a Thermoscreens appointed technician.

Clean and inspect the inside of the air curtain as follows:

Step 1 Remove inlet grille by pressing hinges in both side of the panel at the top of the unit. Remove, then, completely and carefully the inlet grille.

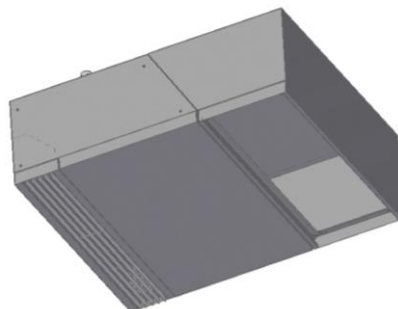
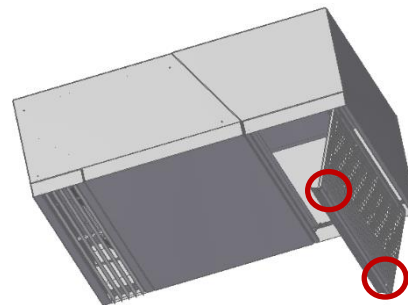
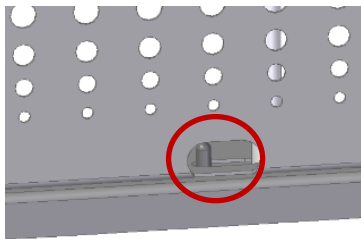

Step 2 Remove the inlet grille frame by unscrewing the 6 off M6 x 20



Step 3 By using a pozi head screwdriver, unscrew the self-tappers that hold together the inlet plenum to the element bar.

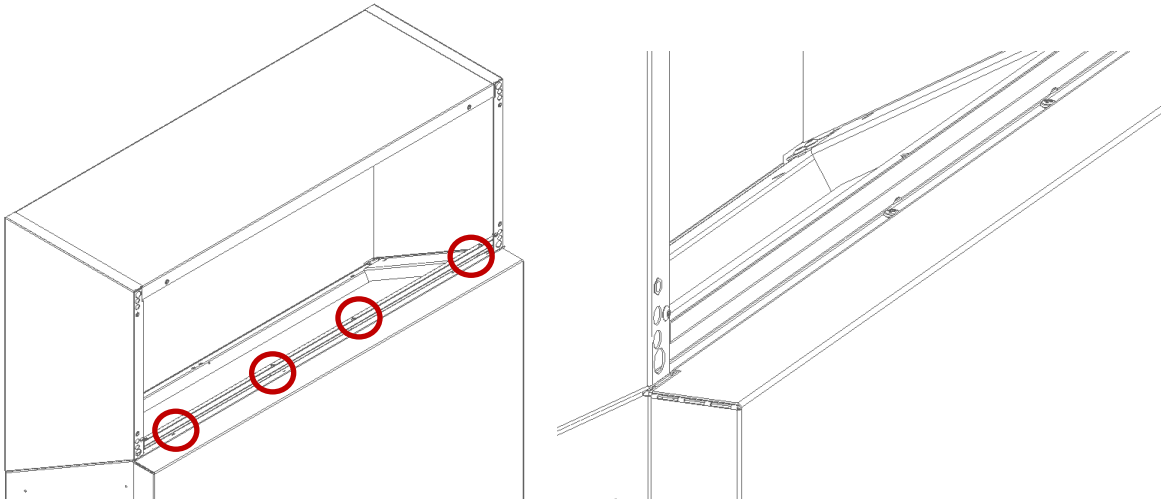

Step 4 By using 8mm nut runner remove M5x20 head set screws at the top of the inspection panel. When they are removed. Pull upwards the panel to unclick it from the casing.

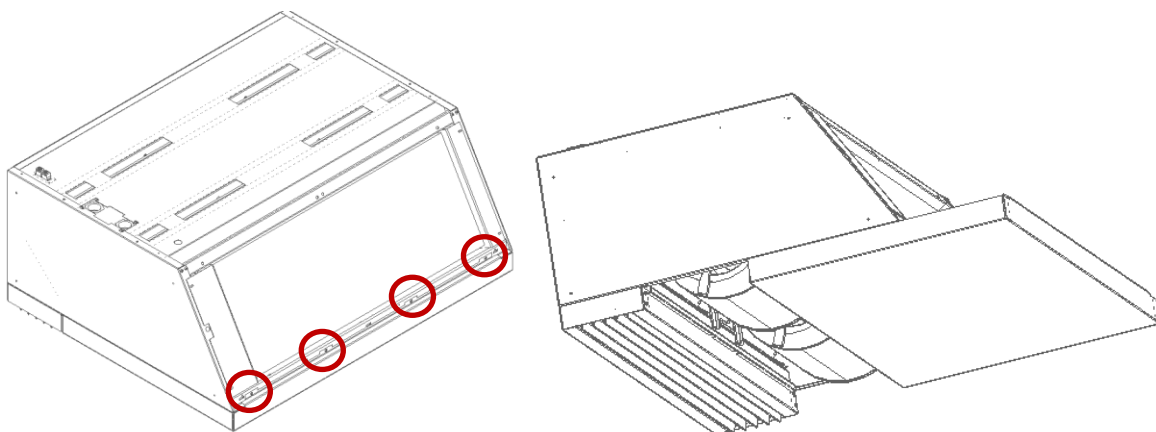

Step 5 Clean and remove any build-up of dust and dirt within the air-curtain (inlet/outlet grilles, electric heaters, fan impellers, housings and motors) using a vacuum cleaner and soft brush.

NOTE: Build-up of dirt on fan impellers can cause vibration, noise and excessive wear on the motor bearings.

Step 6 Check within the unit to ensure all electrical connections and crimped terminals are tight and that all cables are in good condition.

Step 7 Fit inspection panel and inlet plenum. Reconnect electrical supply and test to ensure correct operation (see Section: *“Commissioning the system”*).

TECHNICAL SPECIFICATIONS

Table 4

Electrical Data

Air Curtain Model No	Electrical Supply (V/ph/Hz)	Max Rated Electrical Power Input (kW)	Max Rated Current per phase (A)	Heat Output [Low/High] (kW)	Weight (kg [lb])
PHVX3AR	208/1/60	0.8	3.3	-	86 [190]
PHVX4AR	208/1/60	0.7	4.9	-	100 [220]
PHVX5AR	208/1/60	1.3	5.2	-	122 [251]
PHVX6AR	208/1/60	1.3	5.2	-	136 [300]
PHVX3WR	208/1/60	0.8	3.3	See table 2	96 [212]
PHVX4WR	208/1/60	0.7	4.9	See table 2	109 [240]
PHVX5WR	208/1/60	1.3	5.2	See table 2	134 [295]
PHVX6WR	208/1/60	1.3	5.2	See table 2	149 [329]
PHVX3E208R	208/3/60	14.8	42.2	7 / 14	96 [212]
PHVX4E208R	208/3/60	14.7	43.8	7 / 14	102 [225]
PHVX5E208R	208/3/60*	29.3	44.1/38.9	14 / 28	124 [273]
PHVX6E208R	208/3/60*	29.3	44.1/38.9	14 / 28	138 [304]
PHVX3E480R	480/3/60	14.4	18.4	7 / 14	96 [212]
PHVX4E480R	480/3/60	14.3	19.1	7 / 14	102 [225]
PHVX5E480R	480/3/60	28.6	36.2	14 / 28	124 [273]
PHVX6E480R	480/3/60	28.6	36.2	14 / 28	138 [304]
PHVX3E600R	600/3/60	14.3	14.8	7 / 14	96 [212]
PHVX4E600R	600/3/60	14.3	15.4	7 / 14	102 [225]
PHVX5E600R	600/3/60	28.5	29.0	14 / 28	124 [273]
PHVX6E600R	600/3/60	28.5	29.0	14 / 28	138 [304]

- Unit marked (*) have two supplies of the same voltage to unit.
- “Max Rated Electrical Power” and “Max Rated Current per Phase” are referred to the unit with fans set at 10V.

Product Performance

Fan Speed	Maximum air velocity at outlet grille (m/s [ft/min])	Maximum air curtain mounting height (m [ft])	Sound Pressure Level of air curtain [dB(A) at 3m/9ft 10 in]	Air Volume Flow Rate (m ³ /h [cfm])
HIGH	10.6 [2086] 15.8 [3110] 14.9 [2874] 14.9 [2933]	3.7m [12 ft 2 in]	PHVX3 E/A/W – 69.0 PHVX4 E/A/W – 73.5 PHVX5 E/A/W – 74.3 PHVX6 E/A/W – 77.3	2600 [1530] 3100 [1825] 4500 [2649] 5200 [3060]
MEDIUM	8.9 [1752] 12.2 [2402] 13.0 [2559] 13.0 [2559]	–	PHVX3 E/A/W – 64.8 PHVX4 E/A/W – 67.9 PHVX5 E/A/W – 69.0 PHVX6 E/A/W – 74.7	2200 [1295] 2600 [1530] 3800 [2237] 4500 [2649]
LOW	8.1 [1594] 10.2 [2008] 10.8 [2126] 10.8 [2126]	–	PHVX3 E/A/W – 61.7 PHVX4 E/A/W – 65.6 PHVX5 E/A/W – 64.9 PHVX6 E/A/W – 69.5	1950 [1148] 2100 [1236] 3100 [1825] 3800 [2236]

Sound pressure levels dB(A) at 3m/ 9ft 10in distance are for a single air curtain mounted at its maximum mounting height, operating in a room with average acoustic characteristics as defined in CIBSE Guide B5 (reverberation time 1s) and a room size of 294 m³. Care needs to be taken when selecting air curtains for an installation as noise levels can be several dB higher if the mounting height is reduced, if the room is more 'live' (i.e. hard surfaces, no furnishings or absorbent materials), if the room is smaller than 294 m³ or a combination of these factors. Noise levels will also increase if more than one air curtain is installed at the same doorway (e.g. +3 dB(A) for 2 equal point sources: direct field).

General Product Environment Information

IP Rating	IP20
Maximum Temperature (Storage)	-10°C – 60°C // 14°F - 140°F
Maximum Temperature (Operating – Heating Models)	0°C – 30°C // 32°F - 86°F
Maximum Temperature (Operating – Ambient Models)	0°C – 40°C // 32°F - 104°F
Relative Humidity	95% Non-Condensing

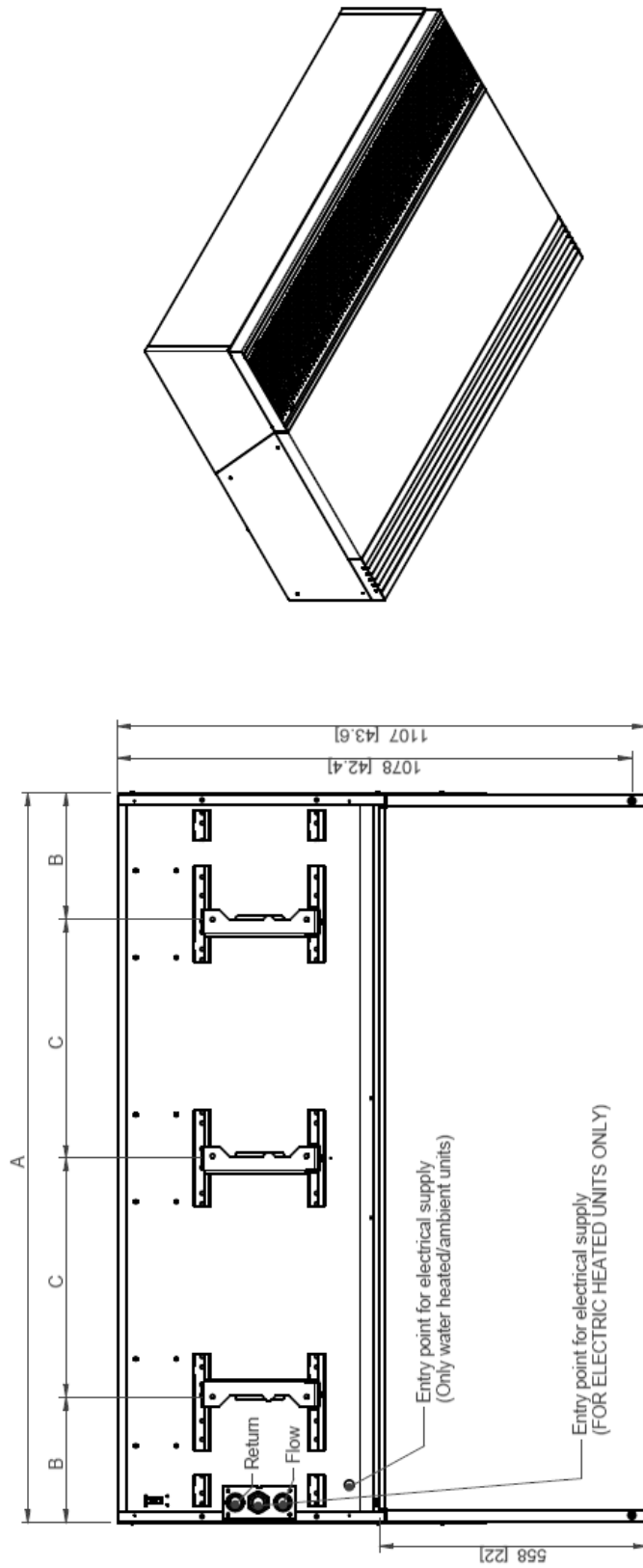

MODEL	A	B	C	Brackets	Rod Drop
PHVX3E/AW	913 [35.9]	265 [10.4]	--	2	4
PHVX4E/AW	1222 [48.1]	265 [10.4]	--	2	4
PHVX5E/AW	1531 [60.3]	265 [10.4]	500 [19.7]	3	6
PHVX6E/AW	1840 [72.4]	265 [10.4]	750 [29.5]	3	6

Note:
Dimensions are noted as: mm [inches]

APPENDIX 1 — Dimensions PHVX Recessed Mounted Air Curtain

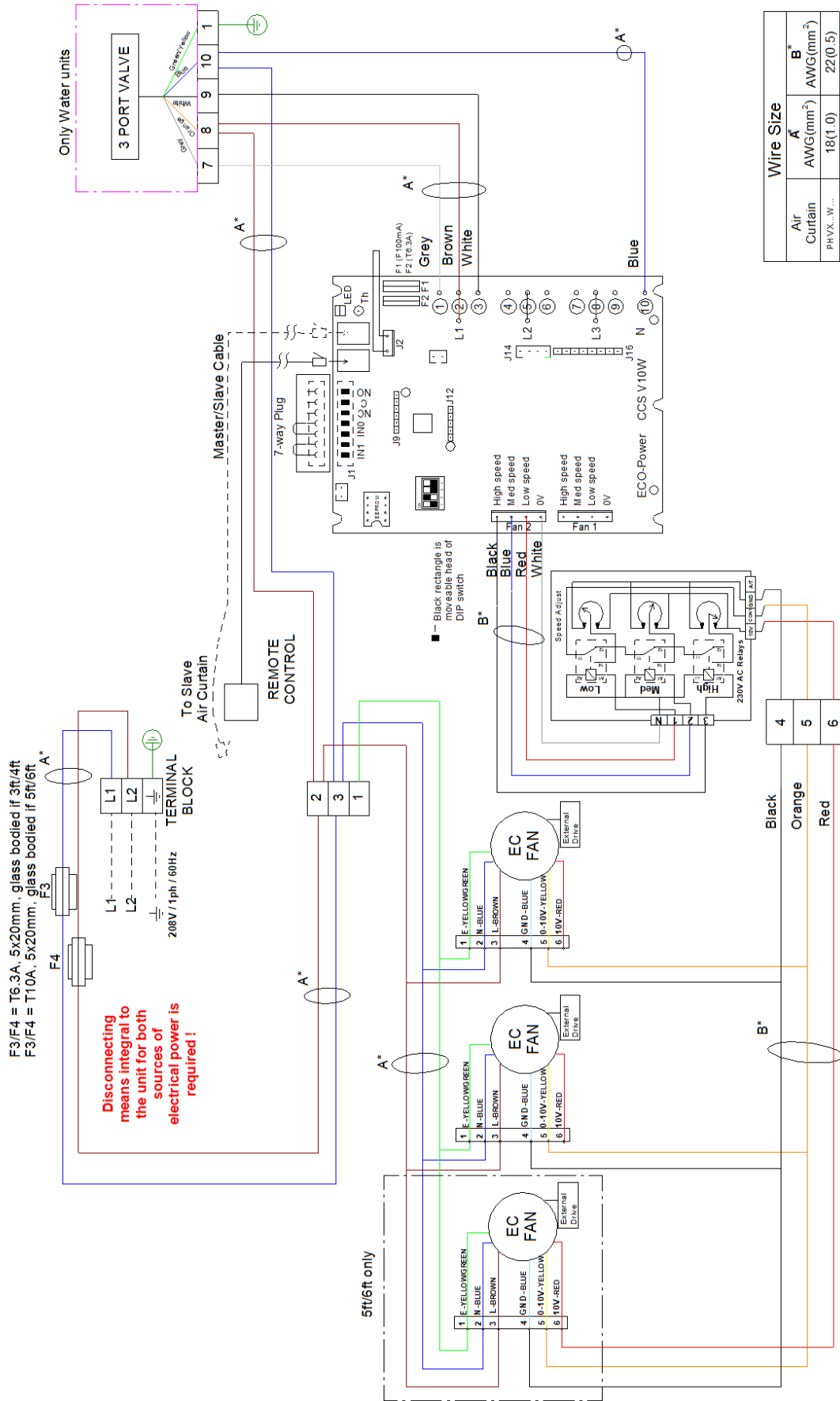

APPENDIX 2 — Wiring diagram NA Recessed Mounted Air Curtain – Ambient/water (all)

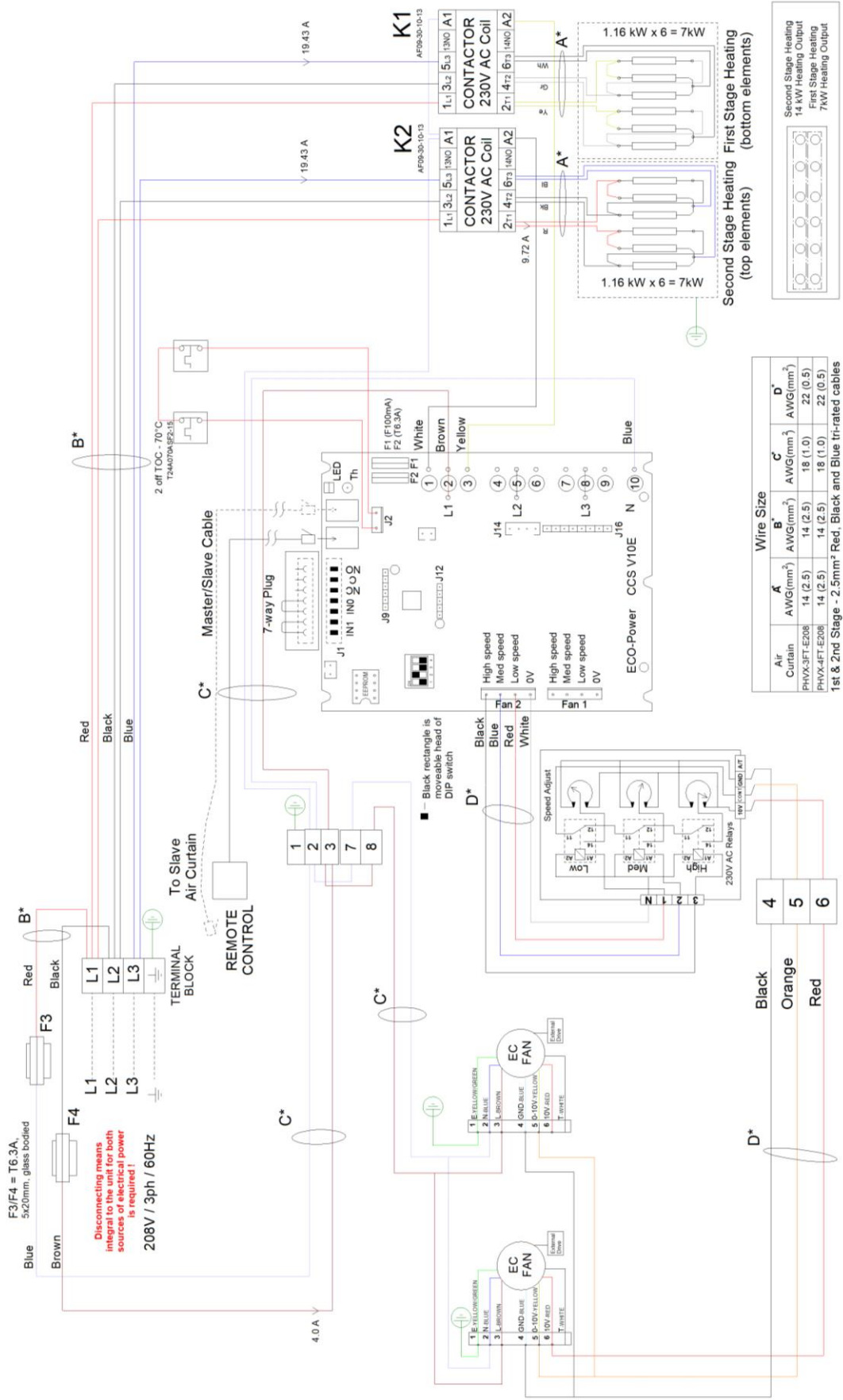

APPENDIX 2 — Wiring diagram PHVX Surface Mounted Air Curtain – E208 (3/4ft)

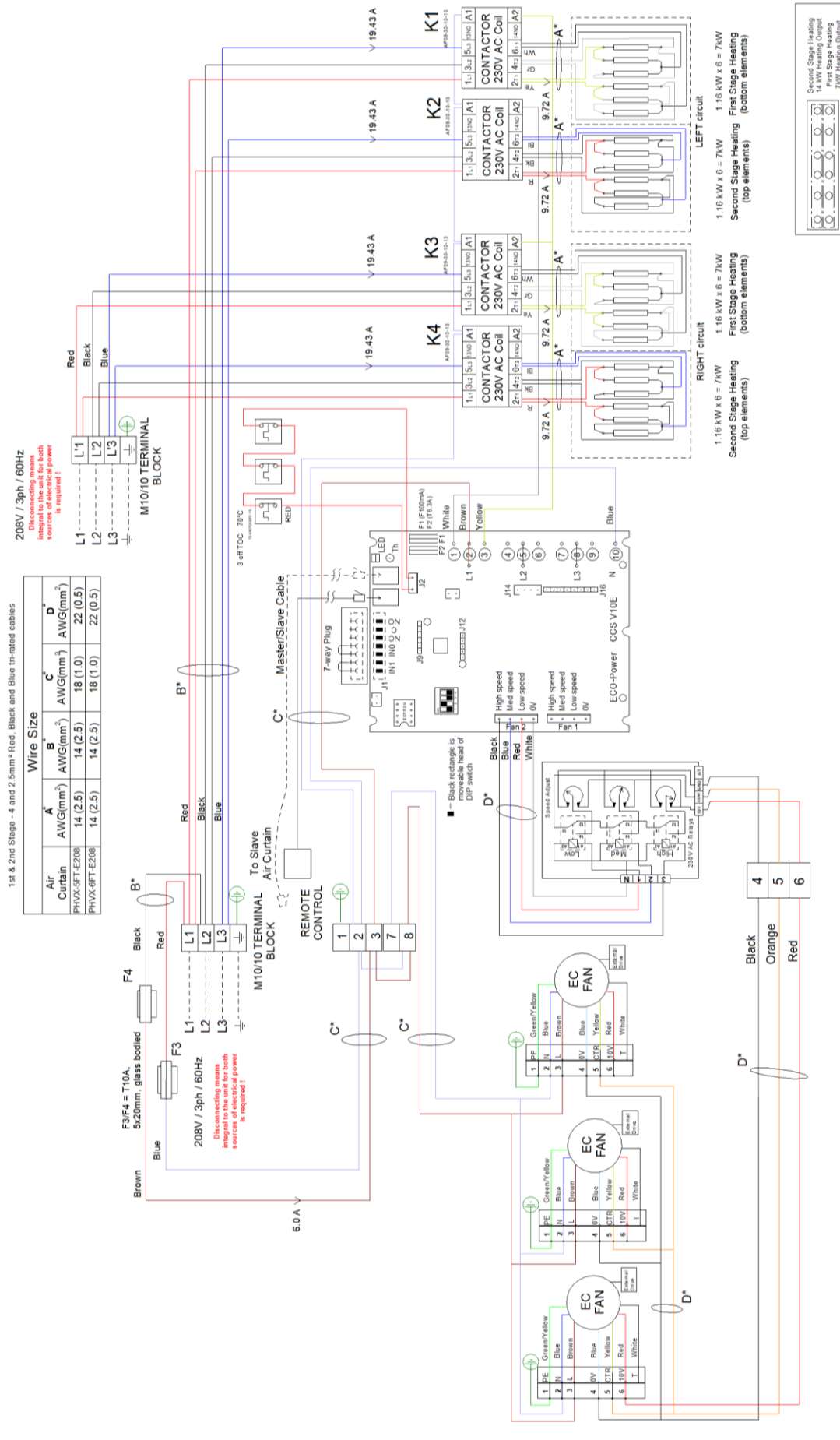

APPENDIX 2 — Wiring diagram PHVX Surface Mounted Air Curtain – E208 (5/6ft)

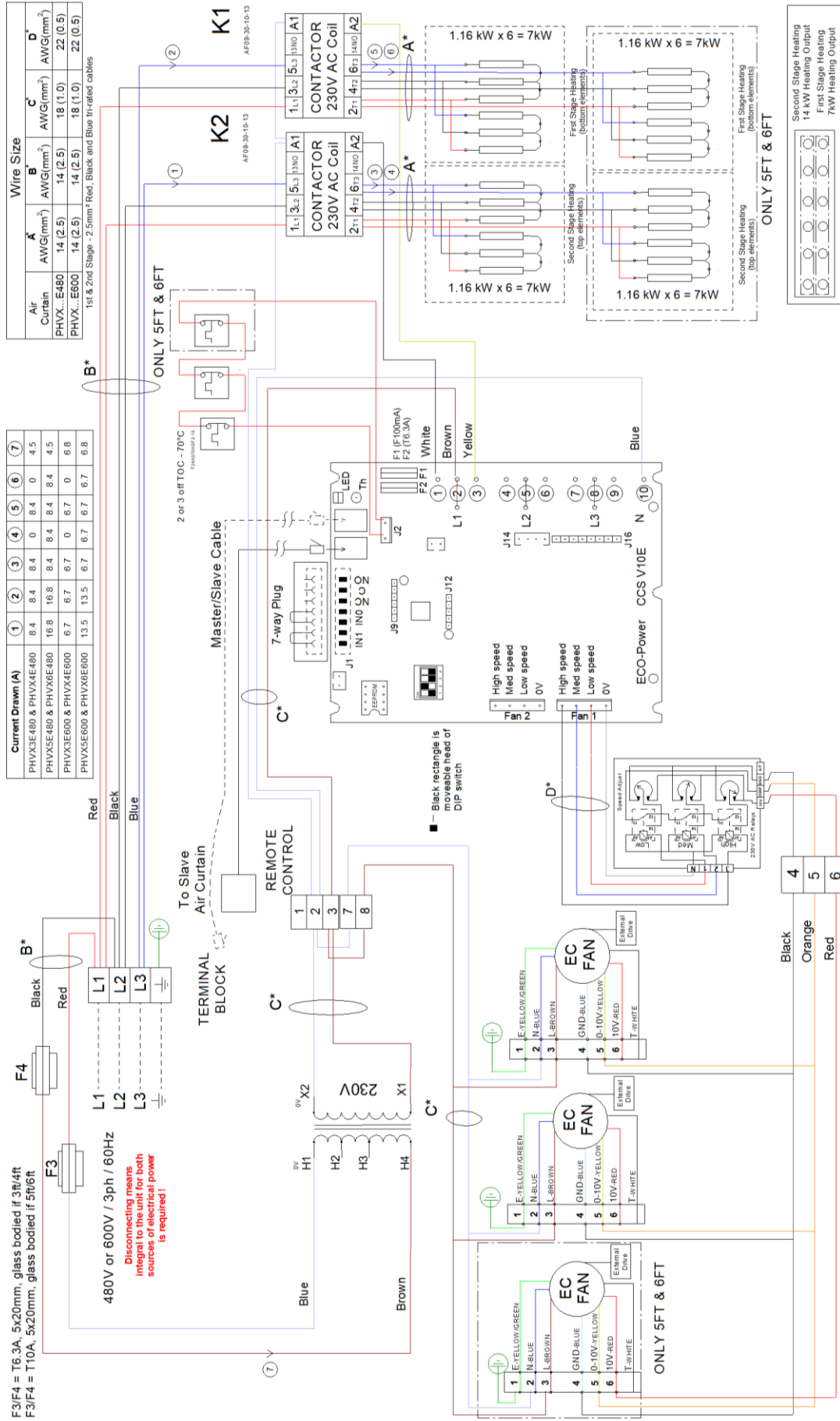

APPENDIX 2 — Wiring diagram PHVX Surface Mounted Air Curtain – E480/600 (all)